



## CLUSTER

Human Settlement, Engineering, and Transport

## UNIT

Engineering

## DEPARTMENT

Roads Provision

### PROCUREMENT DOCUMENT

### INFRASTRUCTURE

Documents are to be obtained, free of charge, in electronic format, from the [National Treasury's eTenders website](#) or the [eThekweni Municipality's website](#).

**Contract No:** 1R-27765

**Contract Title:** Routine structural maintenance repairs to municipal owned retaining walls within the eThekweni Municipality Boundaries for 18 months

**Est. CIDB Grade/ Class:** 4 CE

### CLARIFICATION MEETING AND QUERIES

**Clarification Meeting:** Non-Compulsory Clarification Meeting

**Meeting Location, Date, Time:** Room 213, 2nd floor 30 Archie Gumede Place, Stamford Hill, 4001  
On 19 April 2024 at 11h00

**Queries can be addressed to:** Hlaka Mbina  
**The Employer's Agent's Representative:** Tel: 031-322-3959 Tel  
eMail: [Hlaka.Mbina@durban.gov.za](mailto:Hlaka.Mbina@durban.gov.za). E-mail queries must be submitted by 02 May 2024 and consolidated questions and answers to be uploaded on the website by 09 May 2024.

### TENDER SUBMISSION

**Delivery Location:** The Tender Box in the foyer of the Municipal Building  
166 KE Masinga Road, Durban

**Closing Date/ Time:** Friday, 17 May 2024 at 11h00

**FACSIMILE, eMAIL, or POSTED TENDERS WILL NOT BE ACCEPTED**

**Issued by:**

ETHEKWINI MUNICIPALITY

Deputy Head: Roads Provision

Date of Issue: 12/04/2023

Document Version 24/01/2024

## INDEX to PROCUREMENT DOCUMENT

<b>TENDER PART</b>	<b>Part T1</b>	<b>TENDERING PROCEDURES</b>		<b>Page</b>
		<b>T1.1 Tender Notice and Invitation to Tender</b>		
		T1.1.1 Tender Notice and Invitation to Tender .....		<b>2</b>
		T1.1.2 Notes to Tenderers .....		<b>3</b>
		<b>T1.2 Tender Data</b>		
		T1.2.1 Standard Conditions of Tender .....		<b>5</b>
	T1.2.2 Tender Data ( <i>applicable to this tender</i> ) .....		<b>5</b>	
	T1.2.3 Additional Conditions of Tender .....		<b>15</b>	
	<b>Part T2</b>	<b>RETURNABLE DOCUMENTS</b>		<b>Page</b>
		<b>T2.1 List of Returnable Documents .....</b>		<b>16</b>
<b>T2.2 Returnable Schedules, Forms and Certificates .....</b>			<b>17</b>	

<b>CONTRACT PART</b>	<b>Part C1</b>	<b>AGREEMENT AND CONTRACT DATA</b>		<b>Page</b>
		<b>C1.1 Form of Offer and Acceptance</b>		
		C1.1.1 Offer .....		<b>44</b>
		C1.1.2 Acceptance .....		<b>45</b>
		C1.1.3 Schedule of Deviations .....		<b>46</b>
		<b>C1.2 Contract Data</b>		
		C1.2.1 Standard Conditions of Contract .....		<b>47</b>
		C1.2.2 Contract Data .....		<b>47</b>
		C1.2.3 Additional Conditions of Contract .....		<b>53</b>
		<b>Part C2</b>	<b>PRICING DATA</b>	
	<b>C2.1 Pricing Assumptions / Instructions .....</b>			<b>55</b>
	<b>C2.2 Bill of Quantities (separate page numbering system) .....</b>			<b>57</b>
	<b>Part C3</b>	<b>SCOPE OF WORK</b>		<b>Page</b>
		<b>C3.1 Project Description and Scope of Contract .....</b>		<b>59</b>
		<b>C3.2 Project Specifications .....</b>		<b>60</b>
		<b>C3.3 Standard Specifications .....</b>		<b>70</b>
		<b>C3.4 Particular Specifications .....</b>		<b>85</b>
		<b>C3.5 Contract and Standard Drawings .....</b>		<b>86</b>
		<b>C3.6 Annexures .....</b>		<b>87</b>
	<b>Part C4</b>	<b>SITE INFORMATION</b>		<b>Page</b>
		<b>C4.1 Locality Plan .....</b>		<b>88</b>
		<b>C4.2 Conditions on Site .....</b>		<b>88</b>
<b>C4.3 Test Results .....</b>			<b>88</b>	

## PART T1: TENDERING PROCEDURES

### T1.1.1: TENDER NOTICE AND INVITATION TO TENDER

Tenders are hereby invited for Routine structural maintenance repairs to municipal owned retaining walls within the eThekweni Municipality Boundaries for 18 months.

Subject	Description	Tender Data
<b>Employer</b>	The Employer is the eThekweni Municipality as represented by: Deputy Head: <a href="#">Roads Provision</a>	F.1.1.1
<b>Tender Documents</b>	Documents can only be obtained in electronic format, issued by the eThekweni Municipality. Documentation can be downloaded from the <b>National Treasury's eTenders website</b> or the <b>eThekweni Municipality's Website</b> . The <u>entire document</u> should be printed (on A4 paper) and suitably bound by the tenderer.	F.1.2
<b>CIDB Eligibility</b>	It is <u>estimated</u> that tenderers should have a CIDB contractor grading designation of <b>4 CE</b> (or higher).	<a href="#">F.2.1.1</a>
<b>Clarification Meeting</b>	<a href="#">Room 213, 2nd floor 30 Archie Gumede Place, Stamford Hill, 4001</a> <a href="#">On 19 April 2024 at 11h00</a>	F.2.7
<b>Seek Clarification</b>	Queries relating to these documents are to be addressed to the Employer's Agent's Representative whose contact details are: <a href="#">Hlaka Mbina</a> <a href="#">Tel: 031-322-3959 Tel</a> <a href="#">eMail: <a href="mailto:Hlaka.Mbina@durban.gov.za">Hlaka.Mbina@durban.gov.za</a></a> . <b>E-mail queries must be submitted by 02 May 2024 and consolidated questions and answers to be uploaded on the website by 09 May 2024.</b>	F.2.8
<b>Submitting a Tender Offer</b>	Tender offers shall be delivered to: <a href="#">The Tender Box in the foyer of the Municipal Building</a> <a href="#">166 KE Masinga Road, Durban</a>	F.2.13
<b>Closing Time</b>	Tender offers shall be delivered on or before <a href="#">Friday, 17 May 2024</a> at or before <a href="#">11h00</a> .	F.2.15
<b>Evaluation of Tender Offers</b>	<a href="#">The 80/20</a> Price Preference Point System, as specified in the PPPFA Regulations 2022 will be applied in the evaluation of tenders. Refer to Clause F.3.11 of the Tender Data for the <b>Specific Goal(S)</b> for the awarding of Preference Points, and other related evaluation requirements.	F.3.11

Requirements for sealing, addressing, delivery, opening, and assessment of tenders are stated in the Tender Data

## **T1.1.2: NOTES TO TENDERERS**

These Notes are intended to provide guidance to tenderers regarding tendering obligations and requirements. Compliance requirements are stated in the relevant parts of the Tender Data.

### **eThekwini Supply Chain Management Policy (SCMP)**

The requirements as stated in the Employer's SCM Policy include, but are not limited to, the following:

#### **1) Clause 14(4): ETM Supplier Database**

The eThekwini Supply Chain Management Policy requires suppliers/ service providers/ contractors to be registered on the eThekwini Municipality's Supplier Database (Vendor Portal).

In the event of the Tenderer not being registered on the eThekwini Municipality's Supplier Database, the tenderer must register on the internet at [www.durban.gov.za](http://www.durban.gov.za) by following these links:

- Business
- Supply Chain Management (SCM)
- Accredited Supplier and Contractor's Database.

The following is to be noted:

- The information for registration as in the possession of the eThekwini Municipality will apply.
- It is the Tenderer's responsibility to ensure that the details submitted to the Municipality are correct.
- Tenderers are to register prior to the submission of tenders.

#### **2) Clause 21(1)(d)(i): Audited Financial Statements**

Audited Financial Statements (prepared for auditing) are required to be submitted if the value of the tender offer exceeds R10 million (incl VAT).

#### **3) Clause 21(1)(d)(iii): Contracts Awarded during the past 5 Years**

Tenderers are to include with their submission a listing of any contracts awarded to the tenderer during the past 5 years, including particulars of any material non-compliance or dispute concerning the execution of the contracts. Tenderers are referred to **Returnable Form T2.2.3**.

#### **4) Clause 21(1)(d)(ii), Clause 28(1)(c) and Clause 29(10): Municipal Fees**

Tenderers are to be referred to **Returnable Form T2.2.12**: "Declaration of Municipal Fees", to certify that they have no undisputed commitments for municipal services towards a municipality. Prior to an award, a Tenderer's municipal rates and taxes cannot be in arrears. Should a Tenderer be in arrears with respect to municipal services and has formalised an agreement with the respective municipality to offset the arrears, the agreement must be in place at time of tender closing.

#### **5) Clause 28(1)(d), Clause 28(1)(h) and Clause 29(10): Certifications and Registrations**

CIDB Registration and Status, B-BBEE Certificates, and Tax Compliance Status PIN must be valid at tender closing, and before final award.

The Tenderer's Tax Compliance Status, CIDB Registration and Status, and B-BBEE Level Status (if required), will be confirmed using the National Treasury Central Supplier Database (CSD). Tenderers are referred to **Returnable Form T2.2.1**.

It is the Tenderer's responsibility to ensure that their data on the CSD is kept updated and correctly reflects the status of the tendering entity.

**6) Clause 28(1)(e): Joint Ventures (JV)**

Each party of a JV must submit separate Tax Compliance Status PINs.

Also, and unless otherwise stated, the requirements for a single entity submission in terms of documentation requirements, will apply to each member of a JV making a submission.

As proof that a JV has been formalised, or that the parties to the JV agree to formalise the JV should they be successful in being recommended for the award of this tender, Tenderers are referred to **Returnable Form T2.2.10**.

**CIDB Regulation 25(8)**

- 7) It should be noted that this contract is not part of a **Targeted Development Programme (TDP)**. The CIDB provisions in relation to a Contractor's **Potentially Emerging (PE) status** do not apply. Tenderers are referred to **CIDB Inform Practice Note #32**: "Application of the Potentially Emerging (PE) Status".

**Test for Responsiveness**

- 8) In this regard, Tenderers are referred to **Clause F.3.8** of the Tender Data.

## **PART T1: TENDERING PROCEDURES**

### **T1.2: TENDER DATA**

#### **T1.2.1 STANDARD CONDITIONS OF TENDER**

The conditions of tender are the Standard Conditions of Tender as contained in Annex F of the CIDB Standard for Uniformity in Construction Procurement (July 2015) as published in Government Gazette No 38960, Board Notice 136 of 2015 of 10 July 2015.

The Standard Conditions of Tender make several references to the Tender Data for details that apply specifically to this tender. The Tender Data shall have precedence in the interpretation of any ambiguity or inconsistency between it and the Standard Conditions of Tender.

#### **T1.2.2 TENDER DATA**

Each item of data given below is cross-referenced to the clause in the Standard Conditions of Tender to which it mainly applies.

### **F.1: GENERAL**

**F.1.1 The employer:** The Employer for this Contract is the eThekweni Municipality as represented by: Deputy Head: [Roads Provision](#)

**F.1.2 Tender documents:** The Tender Documents issued by the Employer comprise:

- 1) This procurement document.
- 2) "General Conditions of Contract for Construction Works – 3<sup>rd</sup> Edition 2015" issued by the South African Institution of Civil Engineering (GCC 2015). This document is obtainable separately, and Tenderers shall obtain their own copies.
- 3) "City of Durban Technical Specifications" hereinafter referred to as the Standard Engineering Specifications. This document is obtainable separately, and Tenderers shall obtain their own copies of the applicable Sections.
- 4) Drawings, issued separately from this document, or bound in Section C3.4 (as an Annexure).
- 5) In addition, Tenderers are advised, in their own interest, to obtain their own copies of the following acts, regulations, and standards referred to in this document as they are essential for the Tenderer to get acquainted with the basics of construction management, the implementation of preferential construction procurement policies, and the participation of targeted enterprise and labour.
  - The Employer's current (as at advertising date) Supply Chain Management Policy.
  - The Preferential Procurement Policy Framework Act No 5 of 2000, and the Preferential Procurement Policy Framework Act Regulations (2022).
  - The Occupational Health and Safety Act No 85 and Amendment Act No 181 of 1993, and the Construction Regulations (2014).
  - The Construction Industry Development Board Act No 38 of 2000 and the Regulations issued in terms of the Act (July 2013).
  - SANS 1921:2004 – Construction and Management Requirements for Works Contract, Parts 1-3.
  - Any other eThekweni Policy documents referenced in the Tender Documents.

Electronically downloaded documentation is obtainable from the National Treasury's **eTenders Website** or the **eThekwini Municipality's Website** at URLs:

- <https://www.etenders.gov.za/>
- <https://www.durban.gov.za/pages/business/procurement>

The entire downloaded document should be printed on white A4 paper (single-sided) and suitably bound by the tenderer.

**F.1.4 Communication and employer's agent:** The Employer's Agent is:

Name: [Peter Fenton](#)  
Tel: [031-311-7671](#) Tel  
eMail: [Peter.Fenton@durban.gov.za](mailto:Peter.Fenton@durban.gov.za)

The Employer's Agent's Representative is:

**[Hlaka Mbina](#)**

**[Tel: 031-322-3959](#) Tel**

**[eMail: Hlaka.Mbina@durban.gov.za](mailto:Hlaka.Mbina@durban.gov.za). E-mail queries must be submitted by 02 May 2024 and consolidated questions and answers to be uploaded on the website by 09 May 2024.**

The Tenderer's contact details, as indicated on **Returnable Document T2.2.1: "Compulsory Enterprise Questionnaire"**, shall be deemed as the only valid contact details for the Tenderer for use in communications between the Employer's Agent and the Tenderer during tender evaluation.

## F.2: TENDERER'S OBLIGATIONS

**F.2.1.1 Eligibility: General**

A Tenderer will not be eligible to submit a tender if:

- In the event of a Compulsory Clarification Meeting:
  - the Tenderer fails to attend the Compulsory Clarification Meeting.
  - the Tenderer fails to have **Returnable Document T2.2.2: "Certificate of Attendance at Clarification Meeting / Site Inspection"** signed by the Employer's Agent or his representative.
- at the time of tender closing, the Tenderer is not registered on the **National Treasury Central Supplier Database (CSD)** as a service provider. In the case of a Joint Venture, this requirement will apply individually to each party in the Joint Venture.
- in the case of Joint Venture (JV) submissions, two or more JV entities have common directors / shareholders or common entities tendering for the same works.

**F.2.1.2 Eligibility: CIDB**

Tenderers are to reference the provisions of **Clause F.2.23: "Certificates"** and **Returnable Document T2.2.15: "Verification of CIDB Registration and Status"** with respect to CIDB registration.

Only those tenderers who are registered (as “Active”) with the CIDB (at time of tender closing), in a contractor grading designation equal to or higher than a contractor grading designation determined in accordance with the sum tendered, or a value determined in accordance with Regulation 25 (1B) or 25(7A) of the Construction Industry Development Regulations, for a **CE** class of construction work, are eligible to have their tenders evaluated.

Joint ventures are eligible to submit tenders provided that:

- (a) Every member of the joint venture is registered (as “Active”) with the CIDB (at time of tender closing),
- (b) The lead partner has a contractor grading designation in the **CE** class of construction work and has a grading designation of not lower than one level below the required grading designation, and
- (c) The combined contractor grading designation calculated in accordance with the Construction Industry Development Regulations (2013) is equal to or higher than a contractor grading designation determined in accordance with the sum tendered for a **CE** class of construction work or a value determined in accordance with Regulation 25 (1B) or 25(7A) of the Construction Industry Development Regulations.

#### F.2.1.3 Eligibility: Tenderer’s Experience

Tenderers are to complete and sign **Returnable Form T2.2.16: “Eligibility: Experience of Tenderer”** (4 pages).

Only those tenderers that can demonstrate experience and submit the associated documentation/ information, in works of a similar nature, within the past 10 years, will be eligible to have their tenders evaluated in terms of Clause F.3.11.

- **Table 1:** The **Experience Requirement** is specified on this table.
- **Table 2:** The experience is to be **Similar in Nature** to that specified on this table. Tenderers are to note the exclusions (if any) stated on this table.
- **Table 3:** The **Documentation/ Information** that is required to be included in this submission is specified on this table (which includes the Notes below the table).
- Tenderers may submit experience gained as **Sub-Contractors or Main Contractors**.
- **Guidance** on the completion of the **Experience Submission Form** is provided on the first page of **Returnable Form T2.2.16**.

Tenderers are to indicate the documentation that has been included in the tender submission, in support of each experience submission, in the shaded column on **page 39**.

Should there be insufficient evidence for verification of the information submitted for any specific experience submission, that experience submission may be deemed invalid.

<b>Table 1: Experience Requirement</b>
A minimum of 3 contracts, with works of a similar nature, within the past 10 years, <u>each</u> with a value of 50% of the tender value submitted for this tender on the <b>Form of Offer (C1.1.1)</b> .



<b>Table 2: Works of a Similar Nature</b>
<b>Provision or Maintenance of Road-Related Structures</b>
<ul style="list-style-type: none"> <li>• Projects of a similar nature that will be considered will be one, or a combination of, the following types of projects: <ul style="list-style-type: none"> <li>○ Retaining walls (reinforced concrete, masonry, gabion, proprietary block systems etc).</li> <li>○ Reinforced concrete construction.</li> <li>○ Reinforced concrete repairs (spalling, member replacement, use of specialist products etc).</li> <li>○ Reinforced concrete pedestrian bridges.</li> </ul> </li> </ul>

<b>Table 3: Documentation / Information Requirements</b>				
Note: an "X" in this table indicates that the associated documentation should be provided, if applicable.	Works as Sub-Contractor		Works as Main Contractor	
	Current Contracts	Completed Contracts	Current Contracts	Completed Contracts
Proof of Sub-Contract Agreement <b>See Note 1.</b>	X	X	-	-
Letter of Award OR Form of Offer & Acceptance <b>See Note 2.</b>	-	-	X	X
Most recent Payment Certificate OR Invoice with Quantities summary. <b>See Note 3.</b>	X	-	X	-
Final Payment Certificate OR Invoice with Quantities summary. <b>See Note 4.</b>	-	X	-	X
Completion Certificate. <b>See Note 5.</b>	-	-	-	X
Scope of Work <b>See Note 6.</b>	To be indicated on individual experience submission form			

**NOTES** (for Table 3)

1. To include the names of the parties, the managing entity's name, the effective dates, and the signature(s) page, all pertaining to the agreement.
2. Issued by the Client / Employer.
3. Proof of the most recent payment received from the Main Contractor or Client/ Employer, OR most recent submitted INVOICE, with a summary breakdown of quantities.
4. Proof of the final payment received from the Main Contractor or Client/ Employer, OR most recent submitted INVOICE, with a summary breakdown of quantities.
5. Issued by the Client/ Employer.
6. If executed as a Sub-Contractor, the Scope-of-Work should be indicative of only the works carried out by the Sub-Contractor, and not the overall Scope-of-Work of the main contract.  
If executed as a Main Contractor, the overall contract Scope-of-Work is to be indicated.

**F.2.2.2 The cost of the tender documents:** Replace this paragraph with the following:

"Documents are to be obtained, free of charge, in electronic format, from the **National Treasury's eTenders website** or the **eThekwini Municipality's Website**. The entire electronically downloaded document should be printed on white A4 paper (single-sided) and suitably bound by the tenderer.

**F.2.6 Acknowledge addenda:** Add the following paragraphs to the clause:

“Addenda will be published, in electronic format, on the websites specified in Clause F.1.2. Tenderers are to ensure that the eTenders website is consulted for any published addenda pertaining to this tender up to three days before the tender closing time as stated in the Tender Data.”

“Acknowledgement of receipt of the addenda will be by the return of the relevant completed, dated, and signed portion of the addenda, to the physical or email address as specified on the addenda. Failure of the tenderer to comply with the requirements of the addenda may result in the tender submission being made non-responsive.”

**F.2.7 Clarification meeting:**

**Room 213, 2nd floor 30 Archie Gumede Place, Stamford Hill, 4001  
On 19 April 2024 at 11h00**

In the event of a Compulsory Clarification Meeting, Tenderers must sign the attendance register in the name of the tendering entity. The Tenderer's representative(s) at the clarification meeting must be able to clearly convey the discussions at the meeting to the person(s) responsible for compiling the entity's tender offer.

**F.2.12 Alternative tender offers:** No alternative tender offers will be considered.**F.2.13 Submitting a tender offer:** Submissions must be submitted on official submission documentation issued (either in hard copy or in electronic format) by the eThekweni Municipality.

Should the **Form of Offer** (C1.1.1) and/ or any part of the **Pricing Data** (C2.2) be completed using erasable ink OR pencil, the tender offer will be deemed non-responsive.

Identification details to be shown on each tender offer package are:

- Contract No. : **1R-27765**
- Contract Title : **Routine structural maintenance repairs to municipal owned retaining walls within the eThekweni Municipality Boundaries for 18 months**

The Employer's address for delivery of tender offers is:

**The Tender Box in the foyer of the Municipal Building  
166 KE Masinga Road, Durban**

Tenderers are to include, with their paper submission (“hard copy”), a memory-stick containing an electronically scanned (300 dpi resolution) Public Document Format (PDF) copy of their complete bid submission. This PDF file should be named using the contract number and the Tenderer's name, eg. “**1R-27765 – Tenderers Name.PDF**”. The memory-stick must be labelled with the Tenderer's name and securely fixed to the paper submission.

Telephonic, telegraphic, telex, facsimile or e-mailed tender offers will not be accepted.

**F.2.15 Closing time:** The closing time for delivery of tender offers is:

- Date : **Friday, 17 May 2024**
- Time : **11h00**

**F.2.16 Tender offer validity:** The Tender Offer validity period is **120 Days** from the closing date for submission of tenders.

**F.2.23 Certificates:** Refer to **T2.1: “List of Returnable Documents”** for a listing of certificates that must be provided with the tender. All certificates must be valid at the time of tender closing.

**Tenderers are to include at the back of their tender submission a printout of the required documents/ certificates.**

#### **Compensation Commissioner**

Reference is to be made to **Returnable Document T2.2.13: “Registration with Compensation Commissioner”**.

If required to be registered in terms of the Occupational Injuries and Diseases Act (130 of 1993 as amended), the Tenderer is to supply proof of being registered and in good standing with the compensation fund by submitting a valid **Letter of Good Standing** from the Compensation Commissioner.

Should the Tenderer’s **Letter of Good Standing** be expired at time of tender closing, but an application for renewal has been made, the Tenderer is to include the expired **Letter of Good Standing AND** proof of application for renewal.

Separate **Letters of Good Standing** are required for each party to a Joint Venture.

#### **Central Supplier Database (CSD)**

Reference is to be made to **Returnable Document T2.2.14: “CSD Registration Report”**.

The entities (full) **CSD Registration Report**, obtained from the National Treasury Central Supplier Database, is to be included in the tender submission ( <https://secure.csd.gov.za> ).

The date of the report, as indicated at the top right of each page, should be on or after the date of advertising of this tender.

Separate **CSD Registration Reports** are required for each party to a Joint Venture.

#### **CIDB Registration**

Reference is to be made to **Returnable Document T2.2.15: “Verification of CIDB Registration and Status”**.

Tenderers are to include with their submission a printout of their **CIDB Registration**, obtained from the CIDB website ( <https://registers.cidb.org.za/PublicContractors/ContractorSearch> ).

Separate **CIDB Registration printouts** are required for each party to a Joint Venture.

The date of obtaining the CIDB printout(s) is to be indicated on the printout, and the Tenderer’s registration with the CIDB must be reflected as “Active” as at the date of tender closing.

The **Joint Venture Grading Designation Calculator** printout should also be included when making a submission as a Joint Venture:

( <https://registers.cidb.org.za/PublicContractors/JVGradingDesignationCalc> ).

### F.3: THE EMPLOYER'S UNDERTAKINGS

**F.3.1.1 Respond to requests from the tenderer:** Replace the words “five working days” with “three working days”.

**F.3.2 Issue addenda:** Add the following paragraph: “Addenda will be published, in electronic format, on the same platform(s) as the Tender Notification (refer to **Clause F.1.2**).

**F.3.4 Opening of Tender Submissions:** Tenders will be opened immediately after the closing time for tenders. The public reading of tenders will take place in the SCM Boardroom, 6<sup>th</sup> Floor, Engineering Unit Building, 166 KE Masinga Road, Durban.

**F.3.8 Test for Responsiveness**

Add the following:

F.3.8.3 “Unless otherwise stated in the tender documentation, the following will be deemed as non-material deviations or omissions, applicable to the documents listed below:

- non-submission of required documentation (including attachments).
- the submission of expired versions of required documentation.
- the submission of incomplete, or unsigned, returnable documentation.”

“The above is applicable to the following returnable documents:

- T2.2.1: Compulsory Enterprise Questionnaire
- T2.2.3: Contracts Awarded by Organs of State in the past 5 years
- T2.2.4: Contractor's Health and Safety Declaration
- T2.2.5: MBD 4: Declaration of Interest
- T2.2.6: MBD 5: Declaration for Procurement Above R10 Million
- T2.2.8: MBD 8: Declaration of Bidder's Past SCM Practices
- T2.2.9: MBD 9: Certificate of Independent Bid Determination
- T2.2.10: Joint Venture Agreements (if applicable)
- T2.2.12: Declaration of Municipal Fees
- T2.2.13: Registration with Compensation Commissioner
- T2.2.14: CSD Registration Report
- T2.2.15: Verification of CIDB Registration and Status”

F.3.8.4 “Should the Employer require the rectification of the non-conforming, non-material, deviation(s) and/ or omission(s), the Tenderer will be requested to address such rectification, within a specified time period, prior to the award of the contract. Failure to provide the rectified documentation within the specified time period will result in the tender offer being deemed non-responsive.”

F.3.8.5 “It must be emphasised that any request for the rectification of deviations or omissions cannot:

- detrimentally affect the scope, quality, or performance of the works identified in the Scope of the Work,
- significantly change the Employer's or the Tenderer's risks and responsibilities under the contract,
- affect the competitive position of other tenderers presenting responsive tenders, if the deviation or omission was rectified.”

**F.3.11 Evaluation of Tender Offers:****Eligibility**

Tenders will be checked for compliance with the ELIGIBILITY requirements, as specified in **Clause F.2.1**. Tenderers not in compliance will be deemed non-responsive.

**Preference Point System**

The procedure for the evaluation of responsive tenders is **PRICE AND PREFERENCE** in accordance with the Employer's current SCM Policy, the Preferential Procurement Policy Framework Act (5 of 2000), and the Preferential Procurement Policy Framework Act Regulations (2022).

**Price Points**

The **80/20** preference points system will be applied. The Formula used to calculate the **Price Points (max. 80)** will be according to that specified Regulation 4.1.

**Preference Points**

Reference is also to be made to T2.2.7: "MBD 6.1: Preference Points Claim".

The Preference Points (**20**) will be derived from points allocated/ claimed for **Specific Goals** as indicated in the table(s) below, according to the specified **Goal/ Category Weightings**.

- **Ownership Goal**  
Goal Weighting: 80%

The tendering entity's **Percentage Ownership**, in terms of the **Ownership Category(s)** listed below, is to be used in the determination of the tenderer's claim for **Preference Points**.

<b>Ownership Categories</b>	<b>Criteria</b>	<b>80/20</b>
<b>Race: Black (w1)</b>	Equals 0%	0.0
	Between 0% and 51%	4.8
	Greater or equal to 51% and less than 100%	9.6
	Equals 100%	12.0
<b>Gender: Female (w2 = 25%)</b>	Equals 0%	0.0
	Between 0% and 51%	1.6
	Greater or equal to 51% and less than 100%	3.2
	Equals 100%	4.0
<b>Maximum Goal Points:</b>		<b>16.0</b>

The **Weightings** of the **Ownership Categories** will be:

- w1 = 75%, w2=25%, (where: w1 + w2 = 100%)

**Proof of claim as declared on MBD 6.1** (1 or more of the following will be used in verifying the tenderer's status)

- Companies and Intellectual Property Commission registration document (CIPC)
- CSD report.
- B-BBEE Certificate of the tendering entity.
- Consolidated BBBEE Certificate if the tendering entity is a Consortium, Joint Venture, or Trust (Issued by verification agency accredited by the South African Accreditation System).
- Agreement for a Consortium, Joint Venture, or Trust.

- **RDP Goal: The promotion of South African owned enterprises**

Goal Weighting: 20%

The tendering entity's **Address** (as stated on the National Treasury Central Supplier Database (CSD) or on the eThekweni Municipality Vendor Portal) is to be used in the determination of the tenderer's claim for **Preference Points** for this Specific Goal.

<b>Location</b>	<b>80/20</b>
Not in South Africa	0.0
South Africa	1.0
Kwa Zulu Natal	2.0
eThekweni Municipality	4.0
<b>Maximum Goal Points:</b>	<b>4.0</b>

**Proof of claim as declared on MBD 6.1** (1 or more of the following will be used in verifying the tenderer's status)

- CSD report

**F.3.13 Acceptance of tender offer:** In addition to the requirements of **Clause F.3.13** of the Standard Conditions of Tender, tender offers will only be accepted if:

- The Tenderer's municipal rates and taxes are not in arrears, or they have made arrangements to meet outstanding municipal fee obligations.
- The Tenderer's tax compliance status has been verified, or they have made arrangements to meet outstanding tax obligations.
- The Tenderer is **registered**, and "**Active**", with the **Construction Industry Development Board** in an appropriate contractor grading designation.
- If required to be so registered, the Tenderer is **registered and is in good standing with the compensation fund or with a licensed compensation insurer**, as applicable to the requirements of The Occupational Injuries and Diseases Act.
- The Tenderer or any of its directors/ shareholders are **not listed on the Register of Tender Defaulters** in terms of the Prevention and Combating of Corrupt Activities Act of 2004 as a person prohibited from doing business with the public sector.
- The Tenderer has not:
  - Abused the Employer's Supply Chain Management System; or
  - Failed to perform on any previous contract and has been given a written notice to this effect.
- The tenderer has completed **Returnable Document T2.2.1: "Compulsory Enterprise Questionnaire"** and there are no conflicts of interest which may impact on the Tenderer's ability to perform the contract in the best interests of the Employer or potentially compromise the tender process.
- The Employer is reasonably satisfied that the tenderer has in terms of the Construction Regulations, 2014, issued in terms of the Occupational Health and Safety Act, 1993, the **necessary competencies and resources to carry out the work safely**.

The Municipality does not bind itself to accept the lowest or any tender. It reserves the right to accept the whole or any part of a tender to place orders. Bidders shall not bind the Municipality to any minimum quantity per order. The successful Tenderer (s) shall be bound to provide any quantities stipulated in the specification.

The municipality has a firm intention to proceed with the work, subject to funding being identified. Notwithstanding clause F.1.1.3 of the Standard Conditions of Tender, the municipality reserves the right to award or not award the tender based on the municipalities available budget.

**F.3.15 Complete adjudicator's contract:** Refer to the [General Conditions of Contract](#) and the [Contract Data](#).

**F.3.17 Copies of contract:** The number of paper copies of the signed contract to be provided by the Employer is [ONE \(1\)](#).

---

**T1.2.3 ADDITIONAL CONDITIONS OF TENDER****T1.2.3.1 Appeals**

In terms of Regulation 49 of the Municipal Supply Chain Management Regulations persons aggrieved by decisions or actions taken by the Municipality, may lodge an appeal within 14 days of the decision or action, in writing to the Municipality. All appeals (clearly setting out the reasons for the appeal) and queries with regard to the decision of award are to be directed to:

The City Manager  
**Attention Ms S. Pillay**      **eMail: [Simone.Pillay@durban.gov.za](mailto:Simone.Pillay@durban.gov.za)**  
P O Box 1394  
DURBAN, 4000

**T1.2.3.2 Prohibition on awards to persons in the service of the state**

Clause 44 of the Supply Chain Management Regulations states that the Municipality or Municipal Entity may not make any award to a person:

- (a) Who is in the service of the State;
- (b) If that person is not a natural person, of which a director, manager, principal shareholder or stakeholder is a person in the service of the state; or
- (c) Who is an advisor or consultant contracted with the municipality or a municipal entity.

Should a contract be awarded, and it is subsequently established that Clause 44 has been breached, the Employer shall have the right to terminate the contract with immediate effect.

**T1.2.3.3 Code of Conduct and Local Labour**

The Tenderers shall make themselves familiar with the requirements of the following policies that are available on web address: <ftp://ftp.durban.gov.za/cesu/StdContractDocs/>:

- Code of Conduct;
- The Use of CLOs and Local Labour.

**T1.2.3.4 Targeted Procurement**

Targeted Procurement provisions are not applicable to this tender.

**T1.2.3.5 Functionality Specification**

Functionality Evaluation is not applicable to this tender.



## **PART T2: RETURNABLE DOCUMENTS**

### **T2.1 LIST OF RETURNABLE DOCUMENTS**

#### **T2.1.1 General**

The Tender Submission Documentation must be submitted in its entirety. All forms must be properly completed and signed as required.

The Tenderer is required to complete and sign each and every Schedule and Form listed below to the best of their ability as the evaluation of tenders and the eventual contract will be based on the information provided by the Tenderer. Failure of a Tenderer to complete the Schedules and Forms to the satisfaction of the Employer will inevitably prejudice the tender and may lead to rejection on the grounds that the tender is non-responsive.

#### **T2.1.2 Returnable Schedules, Forms and Certificates**

##### **Entity Specific**

T2.2.1	Compulsory Enterprise Questionnaire	18
T2.2.2	Certificate of Attendance at Clarification Meeting/ Site Inspection	19
T2.2.3	Contracts Awarded by Organs of State in the past 5 years	20
T2.2.4	Contractor's Health and Safety Declaration	21
T2.2.5	MBD 4: Declaration of Interest	23
T2.2.7	MBD 6.1: Preference Points Claim Form ITO the Preferential Regulations	25
T2.2.8	MBD 8: Declaration of Bidder's Past SCM Practices	27
T2.2.9	MBD 9: Certificate of Independent Bid Determination	29
T2.2.10	Joint Venture Agreements (if applicable)	32
T2.2.11	Record of Addenda to Tender Documents (if applicable)	33
T2.2.12	Declaration of Municipal Fees	34
T2.2.13	Registration with Compensation Commissioner	35
T2.2.14	CSD Registration Report	36
T2.2.15	Verification of CIDB Registration and Status	37
T2.2.16	Experience of Tenderer	38

---

## **T2.2 RETURNABLE SCHEDULES, FORMS, AND CERTIFICATES**

The returnable schedules, forms, and certificates, as listed in T2.1.2, can be found on pages [18](#) to [33](#).

### **NOTE**

The following forms in the **Contract Part** of the Documentation are also required to be completed by the tenderer:

- C1.1.1: **Form of Offer,**
- C1.2.2.2: **Data to be Provided by Contractor, and**
- C2.2: **Bill of Quantities.**

**T2.2.1 COMPULSORY ENTERPRISE QUESTIONNAIRE**

Ref	Description	Complete or Circle Applicable	
1.1	Name of enterprise		
1.2	Name of enterprise's representative		
1.3	Email address of representative		
1.4	Contact numbers of representative	Tel:	Cell:
1.5	National Treasury Central Supplier Database Registration number	MAAA	
1.6	eThekwini Supplier Database: Reference number, if any:	PR	
1.7	VAT registration number, if any:		
1.8	CIDB registration number, if any:		
1.9	Department of Labour: Registration number		
1.10	Department of Labour: Letter of Good Standing Certificate number		

2.0 Particulars of sole proprietors and partners in partnerships (attach separate pages if more than 4 partners)			
	Full Name	Identity No.	Personal income tax No. *
2.1			
2.2			
2.3			

3.0 Particulars of companies and close corporations	
3.1	Company registration number, if applicable:
3.2	Close corporation number, if applicable:
3.3	Tax Reference number, if any:
3.4	South African Revenue Service: Tax Compliance Status PIN:

4.0	<b>MBD 4, MBD 6, MBD 8, and MBD9</b> issued by National Treasury must be completed for each tender and be included as a tender requirement.
-----	---

The undersigned, who warrants that he / she is duly authorised to do so on behalf of the enterprise:	
i) authorizes the Employer to verify the tenderers tax clearance status from the South African Revenue Services that it is in order.	
ii) confirms that the neither the name of the enterprise or the name of any partner, manager, director or other person, who wholly or partly exercises or may exercise, control over the enterprise appears on the Register of Tender Defaulters established in terms of the Prevention and Combating of Corrupt Activities Act of 2004.	
iii) confirms that no partner, member, director or other person, who wholly or partly exercises, or may exercise, control over the enterprise appears, has within the last five years been convicted of fraud or corruption.	
iv) confirms that I / we are not associated, linked or involved with any other tendering entities submitting tender offers and have no other relationship with any of the tenderers or those responsible for compiling the scope of work that could cause or be interpreted as a conflict of interest.	
v) confirms that the contents of this questionnaire are within my personal knowledge and are to the best of my belief both true and correct.	

NAME (Block Capitals):

Date

SIGNATURE:

**T2.2.2 CERTIFICATE OF ATTENDANCE AT CLARIFICATION MEETING / SITE INSPECTION**

Reference is to be made to Clauses F.2.1.1(a) and F.2.7 of the Tender Data.

This is to certify that:

(entity name): .....  
of (address): .....  
.....  
.....

was represented by the person(s) named below at the Clarification Meeting held for all tenderers, the details of which are stated in the Tender Data (F.2.7).

I / We acknowledge that the purpose of the meeting was to acquaint myself / ourselves with the site of the works and / or matters incidental to doing the work specified in the tender documents in order for me / us to take account of everything necessary when compiling our rates and prices included in the tender.

**Particulars of person(s) attending the meeting:**

Name: ..... Name: .....  
Signature: ..... Signature: .....  
Capacity: ..... Capacity: .....

**Attendance of the above person(s) at the meeting is confirmed by the Employer's Agent's Representative, namely:**

Name: .....  
Signature: .....  
Date: .....

**T2.2.3 CONTRACTS AWARDED BY ORGANS OF STATE IN THE PAST 5 YEARS**

Tenderers are to provide details of Works undertaken for the Government or Public Sector entities/ Organs of State in the past 5 Years, including particulars of any material non-compliance or dispute concerning the execution of such contract.

Material non-compliance or dispute (Yes or No)												
Date Completed												
Value of Work												
Consulting Engineer/ Engineers representative												
Employer												
Contract Number												

*I, the undersigned, who warrants that they are authorised to sign on behalf of the entity, confirms that the information contained in this form is within my personal knowledge and is to the best of my belief both true and correct.*

**NAME (Block Capitals):**

**Date**

.....

**SIGNATURE:**

.....

**T2.2.4 CONTRACTOR'S HEALTH AND SAFETY DECLARATION**

Reference is to be made to Clauses F.2.1(e) and F.2.23 of the Tender Data.

In terms of Clause 5(1)(h) of the OHS Act 1993 Construction Regulations 2014 (referred to as "the Regulations" hereafter), a Principal Contractor may only be appointed to perform construction work if the Client is satisfied that the Principal Contractor has the necessary competencies and resources to carry out the work safely in accordance with the Occupational Health and Safety Act No 85 of 1993 and the OHS Act 1993 Construction Regulations 2014.

To that effect, a person duly authorised by the tenderer, must complete and sign the declaration hereafter in detail.

**Declaration by Tenderer**

- 1 I, the undersigned, hereby declare and confirm that I am fully conversant with the Occupational Health and Safety Act No 85 of 1993 (as amended by the Occupational Health and Safety Amendment Act No 181 of 1993), and the OHS Act 1993 Construction Regulations 2014.
- 2 I hereby declare that my company has the competence and the necessary resources to safely carry out the construction work under this contract in compliance with the Construction Regulations and the Employer's Health and Safety Specifications.
- 3 I propose to achieve compliance with the Regulations by one of the following **(Tenderers are to Circle Applicable - Yes or No)**:

- (a) From my own competent resources as detailed in 4(a) hereafter.
- (b) From my own resources still to be appointed or trained until competency is achieved, as detailed in 4(b) hereafter:
- (c) From outside sources by appointment of competent specialist Subcontractors as detailed in 4(c) hereafter:

Circle Applicable	
Yes	NO
Yes	NO
YES	NO

- 4 Details of resources I propose:  
*(Note: Competent resources shall include safety personnel such as a construction supervisor and construction safety officer as defined in Regulation 8, and competent persons as defined in Regulations 9, 10, 11, 12, 13, 14, 16, 17, 20, 21, 22, 23(1), 24, 25, 26, 27, 28 and 29, as applicable).*

- (a) Details of the competent and qualified key persons from my company's own resources, who will form part of the contract team:

NAMES OF COMPETENT PERSONS	POSITIONS TO BE FILLED BY COMPETENT PERSONS

(b) Details of training of persons from my company's own resources (or to be hired) who still have to be trained to achieve the necessary competency:

- (i) By whom will training be provided?
- (ii) When will training be undertaken?
- (iii) Positions to be filled by persons to be trained or hired:

(c) Details of competent resources to be appointed as subcontractors if competent persons cannot be supplied from own company:

Name of proposed subcontractor:

Qualifications or details of competency of the subcontractor:

5 I, the undersigned, hereby undertake, if this tender is accepted, to provide, before commencement of the works under the contract, a suitable and sufficiently documented Health and Safety Plan in accordance with Regulation 7(1) of the Construction Regulations, which plan shall be subject to approval by the Client.

6 I, the undersigned, confirm that copies of this company's approved Health and Safety Plan, the Client's Safety Specifications as well as the OHS 1993 Construction Regulations 2014 will be provided on site and will at all times be available for inspection by the Principal Contractor's personnel, the Client's personnel, the Employer's Agent, visitors, and officials and inspectors of the Department of Labour.

7 I, the undersigned, hereby confirm that adequate provision has been made in the tendered rates and prices in the Bill of Quantities to cover the cost of all resources, actions, training and all health and safety measures envisaged in the OHS 1993 Construction Regulations 2014, and that I will be liable for any penalties that may be applied by the Client in terms of the said Regulations (Regulation 33) for failure on the Principal Contractor's part to comply with the provisions of the Act and the Regulations.

8 I, the undersigned, agree that failure to complete and execute this declaration to the satisfaction of the Client will mean that this company is unable to comply with the requirements of the OHS 1993 Construction Regulations (2014) and accept that this tender will be prejudiced and may be rejected at the discretion of the Client.

*I, the undersigned, who warrants that they are authorised to sign on behalf of the Tenderer, confirms that the information contained in this form is within my personal knowledge and is to the best of my belief both true and correct.*

**NAME (Block Capitals):** \_\_\_\_\_ **Date** \_\_\_\_\_

**SIGNATURE:** \_\_\_\_\_

**T2.2.5 MBD 4: DECLARATION OF INTEREST**

MSCM Regulations: **“in the service of the state”** means to be:

- (a) a member of:
  - (i) any municipal council.
  - (ii) any provincial legislature.
  - (iii) the national Assembly or the national Council of provinces.
- (b) a member of the board of directors of any municipal enterprise.
- (c) an official of any municipality or municipal enterprise.
- (d) an employee of any national or provincial department, national or provincial public enterprise or constitutional institution within the meaning of the Public Finance Management Act, 1999 (Act No.1 of 1999).
- (e) a member of the accounting authority of any national or provincial public enterprise.
- (f) an employee of Parliament or a provincial legislature.

**“Shareholder”** means a person who owns shares in the company and is actively involved in the management of the company or business and exercises control over the company.

- 1 No bid will be accepted from persons **in the service of the state**<sup>1</sup>.
- 2 Any person, having a kinship with persons **in the service of the state**, including a blood relationship, may make an offer or offers in terms of this invitation to bid. In view of possible allegations of favouritism, should the resulting bid, or part thereof, be awarded to persons connected with or related to **persons in service of the state**, it is required that the bidder or their authorised representative declare their position in relation to the evaluating/adjudicating authority and/or take an oath declaring his/her interest.
- 3 In order to give effect to the above, the following questionnaire must be completed and submitted with the bid.

3.1 Name of enterprise	
Name of enterprise’s representative	
3.2 ID Number of enterprise’s representative	
3.3 Position enterprise’s representative occupies in the enterprise	
3.4 Company Registration number	
3.5 Tax Reference number	
3.6 VAT registration number	

3.7 The names of all directors / trustees / shareholders / members / sole proprietors / partners in partnerships, their individual identity numbers and state employee numbers must be indicated in paragraph 4 below. In the case of a joint venture, information in respect of each partnering enterprise must be completed and submitted.

3.8 Are you presently in the service of the state?	Circle Applicable		
If yes, furnish particulars: .....	<table border="1" style="margin: auto;"> <tr> <td style="padding: 2px 10px;">YES</td> <td style="padding: 2px 10px;">NO</td> </tr> </table>	YES	NO
YES	NO		
.....			



3.9 Have you been in the service of the state for the past twelve months? YES NO  
 If yes, furnish particulars: .....

3.10 Do you have any relationship (family, friend, other) with persons in the service of the state and who may be involved with the evaluation and or adjudication of this bid? YES NO  
 If yes, furnish particulars: .....

3.11 Are you, aware of any relationship (family, friend, other) between any other bidder and any persons in the service of the state who may be involved with the evaluation and or adjudication of this bid? YES NO  
 If yes, furnish particulars: .....

3.12 Are any of the company's directors, trustees, managers, principle shareholders or stakeholders in service of the state? YES NO  
 If yes, furnish particulars: .....

3.13 Are any spouse, child or parent of the company's directors, trustees, managers, principle shareholders or stakeholders in service of the state? YES NO  
 If yes, furnish particulars: .....

3.14 Do you or any of the directors, trustees, managers, principle shareholders, or stakeholders of this company have any interest in any other related companies or business whether or not they are bidding for this contract? YES NO  
 If yes, furnish particulars: .....

4 The names of all directors / trustees / shareholders / members / sole proprietors / partners in partnerships, their individual identity numbers and state employee numbers must be indicated below. In the case of a joint venture, information in respect of each partnering enterprise must be completed and submitted

Full Name	Identity No.	State Employee No.	Personal income tax No.
Use additional pages if necessary			

*I, the undersigned, who warrants that they are authorised to sign on behalf of the Tenderer, confirms that the information contained in this form is within my personal knowledge and is to the best of my belief both true and correct.*

**NAME (Block Capitals):** \_\_\_\_\_ **Date** \_\_\_\_\_

**SIGNATURE:** \_\_\_\_\_

## **T2.2.7 MBD 6.1: PREFERENCE POINTS CLAIM** **In terms of THE PREFERENTIAL PROCUREMENT REGULATIONS (2022)**

### **Reference is to be made to Clause F.3.11 of the Tender Data.**

This preference form must form part of all tenders invited. It contains general information and serves as a claim form for preference points for specific goals.

**NB: BEFORE COMPLETING THIS FORM, TENDERERS MUST STUDY THE GENERAL CONDITIONS, DEFINITIONS AND DIRECTIVES APPLICABLE IN RESPECT OF THE TENDER AND PREFERENTIAL PROCUREMENT REGULATIONS, 2022**

### **1.0 GENERAL CONDITIONS**

- 1.1 The following preference point systems are applicable to invitations to tender:
  - the 80/20 system for requirements with a Rand value of up to R50 000 000 (all applicable taxes included).
  - the 90/10 system for requirements with a Rand value above R50 000 000 (all applicable taxes included).
- 1.2 The applicable preference point system for this tender is the 80/20 preference point system.
- 1.3 Preference Points for this tender shall be awarded for:
  - **Price and Specific Goals:** Either 80 or 90 (price) and 20 or 10 (specific goals), in terms of 1.2 above.
  - The total Preference Points, for Price and Specific Goals, is 100.
- 1.4 Failure on the part of the tenderer to submit the required proof or documentation, in terms of the requirements in the Conditions of Tender for claiming specific goal preference points, will be interpreted that preference points for specific goals are not claimed.
- 1.5 The Municipality reserves the right to require of a tenderer, either before a tender is adjudicated or at any time subsequently, to substantiate any claim in regard of preferences, in any manner required by the Municipality.

### **2.0 DEFINITIONS**

- 2.1 “**tender**” means a written offer in the form determined by an organ of state in response to an invitation to provide goods or services through price quotations, competitive tendering process or any other method envisaged in legislation.
- 2.2 “**price**” means an amount of money tendered for goods or services, and includes all applicable taxes less all unconditional discounts.
- 2.3 “**rand value**” means the total estimated value of a contract in Rand, calculated at the time of bid invitation, and includes all applicable taxes.
- 2.4 “**tender for income-generating contracts**” means a written offer in the form determined by Municipality in response to an invitation for the origination of income-generating contracts through any method envisaged in legislation that will result in a legal agreement between the Municipality and a third party that produces revenue for the Municipality, and includes, but is not limited to, leasing and disposal of assets and concession contracts, excluding direct sales and disposal of assets through public auctions.
- 2.5 “**the Act**” means the Preferential Procurement Policy Framework Act, 2000 (Act No. 5 of 2000).

### **3.0 FORMULA FOR CALCULATION OF PREFERENCE PRICE POINTS**

#### **3.1 PROCUREMENT OF GOODS AND SERVICES**

**POINTS AWARDED FOR PRICE:** A maximum of 80 or 90 points is allocated for price on the following basis:

$$\begin{array}{ccc}
 \textbf{80 / 20 Points System} & \textbf{OR} & \textbf{90 / 10 Points System} \\
 P_s = 80 \left( 1 - \frac{P_t - P_{min}}{P_{min}} \right) & & P_s = 90 \left( 1 - \frac{P_t - P_{min}}{P_{min}} \right)
 \end{array}$$

Where:  $P_s$  = Points scored for price of tender under consideration,  $P_t$  = Price of tender under consideration,  
 $P_{min}$  = Price of lowest acceptable tender

**4.0 POINTS AWARDED FOR SPECIFIC GOALS**

4.1 In terms of Regulation 4(2); 5(2); 6(2) and 7(2) of the Preferential Procurement Regulations, preference points must be awarded for specific goals stated in the tender. For the purposes of this tender the tenderer will be allocated points based on the goal(s) stated in **Table 1** below, as supported by proof/ documentation stated in the **Conditions of Tender**:

4.2 In cases where organs of state intend to use Regulation 3(2) of the Regulations, which states that if it is unclear whether the 80/20 or 90/10 preference point system applies, an organ of state must, in the tender documents, stipulate in the case of:

- (a) an invitation for tender for income-generating contracts, that either the 80/20 or 90/10 preference point system will apply and that the highest acceptable tender will be used to determine the applicable preference point system, or
- (b) any other invitation for tender, that either the 80/20 or 90/10 preference point system will apply and that the lowest acceptable tender will be used to determine the applicable preference point system,

then the organ of state must indicate the points allocated for specific goals for both the 90/10 and 80/20 preference point system.

**TABLE 1:** Specific Goals for the tender and maximum points for each goal are indicated per the table below. **Tenderers are to indicate their points claim for each of the Specific Goals in the shaded blocks.**

The Specific Goals to be allocated points in terms of this tender	Maximum Number of points ALLOCATED (80/20 system)	Number of points CLAIMED (80/20 system)
Ownership Goal: Race (black)	12.0	
Ownership Goal: Gender (female)	4.0	
RDP Goal: The promotion of South African owned enterprises.	4.0	
<b>Total CLAIMED Points (20 maximum)</b>		

I, the undersigned, who warrants that they are authorised to sign on behalf of the Tenderer, certify that the points claimed, based on the specific goals as specified in the tender, qualifies the tendering entity for the preference(s) shown.

I acknowledge that:

- 1) The information furnished is true and correct.
- 2) The preference points claimed are in accordance with the General Conditions as indicated in paragraph 1 of this form.
- 3) In the event of a contract being awarded as a result of points claimed as shown in paragraphs 1.4 and 4.2, the contractor may be required to furnish documentary proof to the satisfaction of the organ of state that the claims are correct.
- 4) If the specific goals have been claimed or obtained on a fraudulent basis, or any of the conditions of contract have not been fulfilled, the organ of state may, in addition to any other remedy it may have:
  - (a) disqualify the person from the tendering process.
  - (b) recover costs, losses or damages it has incurred or suffered as a result of that person’s conduct.
  - (c) cancel the contract and claim any damages which it has suffered as a result of having to make less favourable arrangements due to such cancellation.
  - (d) recommend that the tenderer or contractor, its shareholders and directors, or only the shareholders and directors who acted on a fraudulent basis, be restricted from obtaining business from any organ of state for a period not exceeding 10 years, after the *audi alteram partem* (hear the other side) rule has been applied; and
  - (e) forward the matter for criminal prosecution, if deemed necessary.

**NAME (Block Capitals):**

**Date**

.....

**SIGNATURE:**

.....

**T2.2.8 MBD 8: DECLARATION OF BIDDER’S PAST SUPPLY CHAIN MANAGEMENT PRACTICES**

- 1.0 This Municipal Bidding Document must form part of all bids invited.
- 2.0 It serves as a declaration to be used by municipalities and municipal entities in ensuring that when goods and services are being procured, all reasonable steps are taken to combat the abuse of the supply chain management system.
- 3.0 The bid of any bidder may be rejected if that bidder, or any of its directors have:
  - a) abused the municipal entity’s supply chain management system or committed any improper conduct in relation to such system.
  - b) been convicted for fraud or corruption during the past five years.
  - c) wilfully neglected, reneged on or failed to comply with any government, municipal or other public sector contract during the past five years.
  - d) been listed in the Register for Tender Defaulters in terms of section 29 of the Prevention and Combating of Corrupt Activities Act (No 12 of 2004).
- 4.0 In order to give effect to the above, the following questions must be completed and submitted with the bid.

4.1 Is the bidder or any of its directors listed on the National Treasury’s Database of Restricted Suppliers as companies or persons prohibited from doing business with the public sector?

(Companies or persons who are listed on this Database were informed in writing of this restriction by the Accounting Officer / Authority of the institution that imposed the restriction after the audi alteram partem rule was applied.)

The Database of Restricted Suppliers now resides on the National Treasury’s website ([www.treasury.gov.za](http://www.treasury.gov.za)) and can be accessed by clicking on its link at the bottom of the home page.

4.1.1 If YES, provide particulars.

.....

.....

Circle Applicable	
YES	NO

4.2 Is the bidder or any of its directors listed on the Register for Tender Defaulters in terms of section 29 of the Prevention and Combating of Corrupt Activities Act (No 12 of 2004)?

The Register for Tender Defaulters can be accessed on the National Treasury’s website ([www.treasury.gov.za](http://www.treasury.gov.za)) by clicking on its link at the bottom of the home page.

4.2.1 If YES, provide particulars.

.....

.....

YES	NO
-----	----

4.3 Was the bidder or any of its directors convicted by a court of law (including a court of law outside the Republic of South Africa) for fraud or corruption during the past five years?

4.3.1 If YES, provide particulars.

.....

.....

YES	NO
-----	----

4.4 Does the bidder or any of its directors owe any municipal rates and taxes or municipal charges to the municipality / municipal entity, or to any other municipality / municipal entity, that is in arrears for more than three months?

YES	NO
-----	----

4.4.1 If YES, provide particulars.

.....

.....

4.5 Was any contract between the bidder and the municipality / municipal entity or any other organ of state terminated during the past five years on account of failure to perform on or comply with the contract?

YES	NO
-----	----

4.5.1 If YES, provide particulars.

.....

.....

*I, the undersigned, who warrants that they are authorised to sign on behalf of the Tenderer, confirms that the information contained in this form is within my personal knowledge and is to the best of my belief both true and correct.*

*I accept that, in addition to cancellation of a contract, action may be taken against me should this declaration prove to be false.*

**NAME (Block Capitals):**

**Date**

**SIGNATURE:**

.....

.....

**T2.2.9 MBD 9: CERTIFICATE OF INDEPENDENT BID DETERMINATION****NOTES**

<sup>1</sup> Includes price quotations, advertised competitive bids, limited bids and proposals.

<sup>2</sup> Bid rigging (or collusive bidding) occurs when businesses, that would otherwise be expected to compete, secretly conspire to raise prices or lower the quality of goods and / or services for purchasers who wish to acquire goods and / or services through a bidding process. Bid rigging is, therefore, an agreement between competitors not to compete.

<sup>3</sup> Joint venture or Consortium means an association of persons for the purpose of combining their expertise, property, capital, efforts, skill and knowledge in an activity for the execution of a contract.

- 1.0 This Municipal Bidding Document (MBD) must form part of all **bids**<sup>1</sup> invited.
- 2.0 Section 4 (1) (b) (iii) of the Competition Act No. 89 of 1998, as amended, prohibits an agreement between, or concerted practice by, firms, or a decision by an association of firms, if it is between parties in a horizontal relationship and if it involves collusive bidding (or **bid rigging**).<sup>2</sup> Collusive bidding is a *pe se* prohibition meaning that it cannot be justified under any grounds.
- 3.0 Municipal Supply Regulation 38 (1) prescribes that a supply chain management policy must provide measures for the combating of abuse of the supply chain management system, and must enable the accounting officer, among others, to:
  - a. take all reasonable steps to prevent such abuse;
  - b. reject the bid of any bidder if that bidder or any of its directors has abused the supply chain management system of the municipality or municipal entity or has committed any improper conduct in relation to such system; and
  - c. cancel a contract awarded to a person if the person committed any corrupt or fraudulent act during the bidding process or the execution of the contract.
- 4.0 This MBD serves as a certificate of declaration that would be used by institutions to ensure that, when bids are considered, reasonable steps are taken to prevent any form of **bid rigging**.
- 5.0 In order to give effect to the above, the attached Certificate of Bid Determination (MBD 9) must be completed and submitted with the bid.

**CERTIFICATE OF INDEPENDENT BID DETERMINATION**

I, the undersigned, in submitting the accompanying bid:

-----  
(Bid Number and Description)

in response to the invitation for the bid made by:

-----  
(Name of Municipality / Municipal Entity)

do hereby make the following statements that I certify to be true and complete in every respect.

I certify, on behalf of:

-----  
(Name of Bidder)

that:

1. I have read and I understand the contents of this Certificate.
2. I understand that the accompanying bid will be disqualified if this Certificate is found not to be true and complete in every respect.
3. I am authorized by the bidder to sign this Certificate, and to submit the accompanying bid, on behalf of the bidder;
4. Each person whose signature appears on the accompanying bid has been authorized by the bidder to determine the terms of, and to sign, the bid, on behalf of the bidder;
5. For the purposes of this Certificate and the accompanying bid, I understand that the word "competitor" shall include any individual or organization, other than the bidder, whether or not affiliated with the bidder, who:
  - (a) has been requested to submit a bid in response to this bid invitation.
  - (b) could potentially submit a bid in response to this bid invitation, based on their qualifications, abilities or experience.
  - (c) provides the same goods and services as the bidder and/or is in the same line of business as the bidder.
6. The bidder has arrived at the accompanying bid independently from, and without consultation, communication, agreement, or arrangement with any competitor. However, communication between partners in a joint venture or consortium<sup>9</sup> will not be construed as collusive bidding.

7. In particular, without limiting the generality of paragraphs 6 above, there has been no consultation, communication, agreement or arrangement with any competitor regarding:
  - (a) prices.
  - (b) geographical area where product or service will be rendered (market allocation).
  - (c) methods, factors or formulas used to calculate prices.
  - (d) the intention or decision to submit or not to submit, a bid.
  - (e) the submission of a bid which does not meet the specifications and conditions of the bid.
  - (f) bidding with the intention not to win the bid.
  
8. In addition, there have been no consultations, communications, agreements, or arrangements with any competitor regarding the quality, quantity, specifications and conditions or delivery particulars of the products or services to which this bid invitation relates.
  
9. The terms of the accompanying bid have not been, and will not be, disclosed by the bidder, directly or indirectly, to any competitor, prior to the date and time of the official bid opening or of the awarding of the contract.
  
10. I am aware that, in addition and without prejudice to any other remedy provided to combat any restrictive practices related to bids and contracts, bids that are suspicious will be reported to the Competition Commission for investigation and possible imposition of administrative penalties in terms of section 59 of the Competition Act No 89 of 1998 and or may be reported to the National Prosecuting Authority (NPA) for criminal investigation and or may be restricted from conducting business with the public sector for a period not exceeding ten (10) years in terms of the Prevention and Combating of Corrupt Activities Act No 12 of 2004 or any other applicable legislation.

**NAME (Block Capitals):** \_\_\_\_\_

**Date**

**SIGNATURE:** \_\_\_\_\_



**T2.2.10 JOINT VENTURES AGREEMENTS**

If this tender submission is to be made by an established Joint Venture, the Joint Venture Agreements and Power of Attorney Agreements are to be attached here.

Should the Joint Venture, at the time of submission, not yet be formalised, this form is to be completed in full and signed by all parties to the proposed Joint Venture.

The Lead Partner of the Joint Venture is to sign the Form of Offer in **Part C1.1.1**.

**INTENT TO FORM A JOINT VENTURE**

Should our submission for CONTRACT: [1R-27765](#) be successful, a Joint Venture will be established by the parties as listed below, as an unincorporated association, with the purposes of securing and executing the Contract, for the benefit of the Members.

**Proposed Joint Venture**

Joint Venture Title (name):

Represented by (name):  Tel:

**Lead Partner/ Member 1**

Entity Name:

Ownership Interest in JV %:  CSD Registration:

CIDB #:  Vendor Portal:

Represented by (name): \_\_\_\_\_ Signature: \_\_\_\_\_

**Partner/ Member 2**

Entity Name:

Ownership Interest in JV %:  CSD Registration:

CIDB #:  Vendor Portal:

Represented by (name): \_\_\_\_\_ Signature: \_\_\_\_\_

**Partner/ Member 3**

Entity Name:

Ownership Interest in JV %:  CSD Registration:

CIDB #:  Vendor Portal:

Represented by (name): \_\_\_\_\_ Signature: \_\_\_\_\_

**Note:** All requirements for Joint Ventures, as stated elsewhere in this procurement document, must be complied with in full.

**T2.2.11 RECORD OF ADDENDA TO TENDER DOCUMENTS**

I / We confirm that the following communications received from the Employer or his representative before the date of submission of this tender offer, amending the tender documents, have been taken into account in this tender offer.

ADD.No	DATE	TITLE OR DETAILS
1		
2		
3		
4		
5		
6		
7		
8		
9		
10		

*I, the undersigned, who warrants that they are authorised to sign on behalf of the Tenderer, confirms that the information contained in this form is within my personal knowledge and is to the best of my belief both true and correct.*

***It is also confirmed that the requirements, as stated on the Addenda, have been complied with.***

**NAME (Block Capitals):**

**Date**

**SIGNATURE:**

.....

.....

**T2.2.12 DECLARATION OF MUNICIPAL FEES**

Reference is to be made to **Clauses F.2.23 and F.3.13(a)** of the Tender Data.

I, the undersigned, do hereby declare that the Municipal fees of:

.....  
 (full name of Company / Close Corporation / partnership / sole proprietary/Joint Venture)

(hereinafter referred to as the TENDERER) are, as at the date hereunder, fully paid or an Acknowledgement of Debt has been concluded with the Municipality to pay the said charges in instalments.

The following account details relate to property of the said TENDERER:

<u>Account</u>	<u>Account Number: to be completed by tenderer</u>										
Consolidated Account											
Electricity											
Water											
Rates											
JSB Levies											
Other											

- If applicable, a copy of a recent (within the past 3 months) Metro Bill is to be provided.

I acknowledge that should the aforesaid Municipal charges fall into arrears, the Municipality may take such remedial action as is required, including termination of any contract, and any payments due to the Contractor by the Municipality shall be first set off against such arrears.

- Where the tenderer’s place of business or business interests are outside the jurisdiction of eThekweni municipality, a copy of the accounts/ agreements from the relevant municipality are to be provided.
- Where the tenderer’s Municipal Accounts are part of their lease agreement, then a copy of the agreement, or an official letter to that effect, is to be provided.
- Where a tenderer’s place of business or business interests are carried out from premises as part of any other agreement, then a copy of the agreement, or an official letter to that effect, is to be provided.

**Tenderers are to include, at the back of their tender submission, copies of the above-mentioned account’s, agreements signed with the municipality, lease agreements, or official letters.**

*I, the undersigned, who warrants that they are authorised to sign on behalf of the Tenderer, confirms that the information contained in this form is within my personal knowledge and is to the best of my belief both true and correct, **and that the requested documentation has been included in the tender submission.***

**NAME (Block Capitals):** \_\_\_\_\_

**Date** \_\_\_\_\_

**SIGNATURE:** \_\_\_\_\_

**T2.2.13 REGISTRATION WITH COMPENSATION COMMISSIONER**

Reference is to be made to **Clauses F.2.23 and F.3.13(d)** of the Tender Data.

The Occupational Injuries and Diseases Act (130 of 1993 as amended) (the Act) refers. A summary of the pertinent Clauses are listed below. The act is to be referenced for the full text of the clauses.

**Clause 80: Employer to register with commissioner and furnish him with particulars**

The Act requires that an Employer carrying out business in the Republic to register with the Compensation Commissioner. Any person who fails to comply with the provisions of the this clause is guilty of an offence.

**Clause 82: Employer to furnish returns of earnings**

The Act requires an Employer to furnish the commissioner with a return showing:

- The amount of earnings paid by him to his employees.
- Any further information as may be prescribed or as the commissioner may require.

Any Employer who fails to comply with the provisions of the this clause is guilty of an offence.

**Clause 86: Assessment to be paid by an employer to commissioner**

The Act states that an Employer will receive notices of assessment from the commissioner. The Employer must pay the commissioner the assessment amount on the notices.

**Clause 89: Mandators and contractors**

The Act requires a contractor (a person with a contract with a mandator) to register as an Employer in accordance with the provisions of the Act and pay the necessary assessments. Failing registration or payment of assessments, the mandator is required to pay the assessments in respect of the employees of the contractor. The mandator is allowed to recover the assessment amounts paid from the contractor.

The Department of labour issues contractors with a **Letter of Good Standing** if the contractor has complied with the requirement(s) of the Act and is in "good standing" with the Compensation Fund. Employers can check the validity of such Letters of Good Standing on the internet (<https://cfoonline.labour.gov.za/VerifyLOGS> ).

**If required to be registered in terms of the Occupational Injuries and Diseases Act, Tenderers are to include, at the back of their tender submission, a printout of their most recent Letter of Good Standing from the Department of Labour, and if application for renewal has been made, proof of such application.**

*I, the undersigned, who warrants that they are authorised to sign on behalf of the Tenderer, confirms that the information contained in this form is within my personal knowledge and is to the best of my belief both true and correct, **and that the requested documentation has been included in the tender submission.***

**NAME (Block Capitals):** \_\_\_\_\_

**Date**

**SIGNATURE:** \_\_\_\_\_

**T2.2.14 CSD REGISTRATION REPORT**

Reference is to be made to **Clauses F.2.1.1(b) and F.2.23** of the Tender Data.

The Conditions of Tender, Clause F.2.1: Eligibility, requires a tenderer to be registered, at the time of tender closing, on the **National Treasury Central Supplier Database (CSD)** as a service provider.

CSD Registration Reports can be obtained from the National Treasury's CSD website at <https://secure.csd.gov.za/Account/Login>.

The date of obtaining the printout is to be indicated on the printout.

The following is an example of the beginning of the printout obtained from the above website.

<b>CENTRAL SUPPLIER DATABASE FOR GOVERNMENT</b>				<b>Report Date:</b>
				<b>Report Ran By:</b>
<b>CSD REGISTRATION REPORT</b>				
<b>SUPPLIER IDENTIFICATION</b>				
Supplier number		Have Bank Account		
Is supplier active?		Total annual turnover		
Supplier type		Financial year start date		
Supplier sub-type		Registration date		
Legal name		Created by		
Trading name		Created date		
Identification type		Edit by		
Government breakdown		Edit date		
Business status		Restricted Supplier		
Country of origin		Restriction Last Verification Date		
South African company/CC registration number				

**Tenderers are to include, at the back of their tender submission, a printout of their (full) CSD Registration Report.**

*I, the undersigned, who warrants that they are authorised to sign on behalf of the Tenderer, confirms that the information contained in this form is within my personal knowledge and is to the best of my belief both true and correct, **and that the requested documentation has been included in the tender submission.***

**NAME (Block Capitals):**

**Date**

.....

**SIGNATURE:**

.....

.....

**T2.2.15 VERIFICATION OF CIDB REGISTRATION AND STATUS**

Reference is to be made to **Clauses F.2.1.2, F.2.23, and F.3.13(c)** of the Tender Data.

The Conditions of Tender, **Clause F.2.1.1: Eligibility**, requires a tenderer to be registered, as "Active", with the CIDB (at time of tender closing), in a contractor grading designation equal to or higher than a contractor grading designation determined in accordance with the sum tendered, or a value determined in accordance with Regulation 25 (1B) or 25(7A) of the Construction Industry Development Regulations.

The required class of construction work is specified in **Clause F.2.1.2** of the Tender Data.

CIDB Registrations can be obtained from the CIDB website at:

<https://registers.cidb.org.za/PublicContractors/ContractorSearch>.

The date of obtaining the printout is to be indicated on the printout.

The following is an example of the beginning of the printout obtained from the above website.

Home

construction industry development board

Contractor Detail Print

Contractor Detail

CRS Number: \_\_\_\_\_ Type of Enterprise: \_\_\_\_\_

Contractor Name: \_\_\_\_\_ Registration Date: \_\_\_\_\_

Trading Name: \_\_\_\_\_ Expiry Date: \_\_\_\_\_

Status: \_\_\_\_\_

Contractor Grades

Grade: \_\_\_\_\_

Back

Copyright © cidb 2011. All rights reserved  
[Website technical enquires: contact](#)

01/01/2017

**Tenderers are to include, at the back of their tender submission, a printout of their registration with the CIDB.**

*I, the undersigned, who warrants that they are authorised to sign on behalf of the Tenderer, confirms that the information contained in this form is within my personal knowledge and is to the best of my belief both true and correct, **and that the requested documentation has been included in the tender submission.***

**NAME (Block Capitals):** \_\_\_\_\_

**Date**

**SIGNATURE:** \_\_\_\_\_

## **T2.2.16 ELIGIBILITY: EXPERIENCE OF TENDERER**

Reference is to be made to F.2.1.3 of the Tender Data.

Only those Tenderers that can demonstrate experience and submit the associated documentation/ information, in works of a similar nature, within the past 10 years, will be eligible to have their tenders evaluated in terms of Clause F.3.11.

- The **Eligibility Criteria Requirement** is as stated on **Table 1: “Experience Requirement”**.
- The experience is to be **“Similar in Nature”** to that specified on **Table 2: “Works of a Similar Nature”**. Tenderers are to note the exclusions (if any) stated on this table.
- The **Documentation/ Information** that is required is specified on **Table 3: “Documentation/ Information Requirements”** (which includes the Notes below the table).
- Tenderers may submit experience gained as **Sub-Contractors or Main Contractors**.

**It is the responsibility of the tenderer to ensure that the experience submissions comply with the requirements as stated in F.2.1.3 of the Tender Data.**

### **Guidance to Tenderers: Experience Submission Form**

#### **Client / Employer Details**

- Provide details for whom the works were carried out (works owner).
- Provide **Contact details of the Client or Main Contractor** (if experience was gained as a sub-contractor) is required to be provided.

The contact details may be used by the Employer to verify the information, pertaining to the experience submission. Should the Employer’s reasonable attempts to make contact with the Client or Main Contractor fail (for whatever reason), that specific experience submission may be considered invalid.

#### **Contract Details**

- Provide the **Contract Reference Number** and **Contract Title**.
- Indicate if this contract has been completed or is still in progress.
- Provide **Contract Dates**.
- Provide **Contract Values** - Where works are still in progress, provide the value of works that have been completed as detailed on the most recent payment to the Contractor / Sub-Contractor. If the works are complete, provide the Final Value of the sub-contract or Final Contract Price.

#### **Scope of Works**

- Indicate the **Works Type(s)** that best describe the works included in the project.  
Select the most applicable option (only 1).
- Indicate the **Works Elements(s)** that were included in the project.  
Select any elements that were included in the contract.

#### **Joint Ventures**

In the event of a Joint Venture (JV) tendering for this contract, experience gained by the separate entities making up the JV may be used as experience, provided that the experience complies with the requirements, as stipulated in **Table 1**, and that the required documentation/ information is provided.

(T2.2.16 is continued on the next page)

**Confirmation of submission of Information/ Documentation**

The Tenderer is to indicate (by marking with an “X” in the shaded column) the documentation that has been included in this tender submission, in support of each experience submission.

		If submitted, mark with an “X”
<b>SUBMISSION #1</b>	Experience Submission Form (completed and signed)	
	Proof of Sub-Contract Agreement (if experience was gained as a sub-contractor)	
	Letter of Award OR Form of Offer & Acceptance	
	Most recent Payment Certificate, OR most recent INVOICE, with Quantities summary	
	Final Payment Certificate, OR most recent INVOICE, with Quantities summary	
	Completion Certificate	
<b>SUBMISSION #2</b>	Experience Submission Form (completed and signed)	
	Proof of Sub-Contract Agreement (if experience was gained as a sub-contractor)	
	Letter of Award OR Form of Offer & Acceptance	
	Most recent Payment Certificate, OR most recent INVOICE, with Quantities summary	
	Final Payment Certificate, OR most recent INVOICE, with Quantities summary	
	Completion Certificate	
<b>SUBMISSION #3</b>	Experience Submission Form (completed and signed)	
	Proof of Sub-Contract Agreement (if experience was gained as a sub-contractor)	
	Letter of Award OR Form of Offer & Acceptance	
	Most recent Payment Certificate, OR most recent INVOICE, with Quantities summary	
	Final Payment Certificate, OR most recent INVOICE, with Quantities summary	
	Completion Certificate	
<b>SUBMISSION #4</b>	Experience Submission Form (completed and signed)	
	Proof of Sub-Contract Agreement (if experience was gained as a sub-contractor)	
	Letter of Award OR Form of Offer & Acceptance	
	Most recent Payment Certificate, OR most recent INVOICE, with Quantities summary	
	Final Payment Certificate, OR most recent INVOICE, with Quantities summary	
	Completion Certificate	

Note: Should there be insufficient evidence for verification of the information submitted for any specific experience submission, that experience submission may be deemed invalid.

*I, the undersigned, who warrants that they are authorised to sign on behalf of the Tenderer, confirms that the information contained in this form is within my personal knowledge and is to the best of my belief both true and correct, and that the requested documentation has been included in the tender submission.*

**NAME (Block Capitals):** .....

**Date**

**SIGNATURE:** .....



**EXPERIENCE SUBMISSION #1**

Reference is to be made to **Clause F.2.1.3** of the Tender Data.

(Where required, in the shaded areas, clearly mark selection with an "X" or circle applicable)

<b>Experience as a:</b>	Sub-Contractor:		Main Contractor:												
<b>Client/ Employer OR Main Contractor's Details</b>  Should the Employer's reasonable attempts to make contact, to verify the information provided, fail (for whatever reason) this experience submission will be considered invalid.	Entity Name:														
	Contact Name:														
	Contact Tel:					-					-				
	Contact Cell:					-					-				
	Contact email / other:														
Enter the Client/ Employer's details, OR, if the works was done as a sub-contractor, enter the Main Contractor's Details															

<b>Contract Details</b>	Contract (Reference) Number:										
	Contract Title:										
	Has this Contract been completed?	Y	N	Commencement Date:	d	d	m	m	2	0	y
			Completion Date (if applicable):	d	d	m	m	2	0	y	y
Tendered Value (Contract Sum) OR Sub-Contract Value:	<b>R</b>	Final Contract Price OR Final Value of Sub-Contract:				<b>R</b>					

**Contract Scope-of-Work (Type of Project and Works Elements):**

<b>Which Works Type(s) best describe the project?</b>		Pedestrian Bridge	
Stormwater related structure (culverts etc)		Road Bridge and related structures	
Retaining structures		Maintenance and repairs to structures	
OTHER: provide a description of the type of project			

<b>Which Works Element(s) were included in the project?</b>		Reinforced concrete construction.	
Retaining walls (reinforced concrete, masonry, gabion, proprietary block systems etc).		Reinforced concrete repairs (spalling, member replacement, use of specialist products etc).	
Reinforced and prestressed concrete pedestrian and road bridges.		Specialist proprietary product repair systems or approved product applicator for specific specialist proprietary products.	
Reinforced concrete pedestrian bridges.		Structural steel construction and repairs and application of steel protection systems.	
Structural steel pedestrian bridges.			
OTHER: List works elements included in project			

**Confirmation of documentation submitted is to be recorded on Page 39.**

*I, the undersigned, who warrants that they are authorised to sign on behalf of the Tenderer, confirms that the information contained in this form is within my personal knowledge and is to the best of my belief both true and correct, and that the requested documentation has been included in the tender submission.*

**NAME (Block Capitals):** \_\_\_\_\_

**Date**

**SIGNATURE:** \_\_\_\_\_

**EXPERIENCE SUBMISSION #2**

Reference is to be made to **Clause F.2.1.3** of the Tender Data.

(Where required, in the shaded areas, clearly mark selection with an "X" or circle applicable)

<b>Experience as a:</b>	Sub-Contractor:		Main Contractor:									
<b>Client/ Employer OR Main Contractor's Details</b>  Should the Employer's reasonable attempts to make contact, to verify the information provided, fail (for whatever reason) this experience submission will be considered invalid.	Entity Name:											
	Contact Name:											
	Contact Tel:											
	Contact Cell:											
	Contact email / other:											
Enter the Client/ Employer's details, OR, if the works was done as a sub-contractor, enter the Main Contractor's Details												

<b>Contract Details</b>	Contract (Reference) Number:										
	Contract Title:										
	Has this Contract been completed?	Y	N	Commencement Date:	d	d	m	m	2	0	y
			Completion Date (if applicable):	d	d	m	m	2	0	y	y
Tendered Value (Contract Sum) OR Sub-Contract Value:	<b>R</b>	Final Contract Price OR Final Value of Sub-Contract:				<b>R</b>					

**Contract Scope-of-Work (Type of Project and Works Elements):**

<b>Which Works Type(s) best describe the project?</b>		Pedestrian Bridge	
Stormwater related structure (culverts etc)		Road Bridge and related structures	
Retaining structures		Maintenance and repairs to structures	
OTHER: provide a description of the type of project			

<b>Which Works Element(s) were included in the project?</b>		Reinforced concrete construction.	
Retaining walls (reinforced concrete, masonry, gabion, proprietary block systems etc).		Reinforced concrete repairs (spalling, member replacement, use of specialist products etc).	
Reinforced and prestressed concrete pedestrian and road bridges.		Specialist proprietary product repair systems or approved product applicator for specific specialist proprietary products.	
Reinforced concrete pedestrian bridges.		Structural steel construction and repairs and application of steel protection systems.	
Structural steel pedestrian bridges.			
OTHER: List works elements included in project			

Confirmation of documentation submitted is to be recorded on Page 39.

*I, the undersigned, who warrants that they are authorised to sign on behalf of the Tenderer, confirms that the information contained in this form is within my personal knowledge and is to the best of my belief both true and correct, and that the requested documentation has been included in the tender submission.*

**NAME (Block Capitals):** \_\_\_\_\_

**Date**

**SIGNATURE:** \_\_\_\_\_

**EXPERIENCE SUBMISSION #3**

Reference is to be made to **Clause F.2.1.3** of the Tender Data.

(Where required, in the shaded areas, clearly mark selection with an "X" or circle applicable)

<b>Experience as a:</b>	Sub-Contractor:		Main Contractor:									
<b>Client/ Employer OR Main Contractor's Details</b>  Should the Employer's reasonable attempts to make contact, to verify the information provided, fail (for whatever reason) this experience submission will be considered invalid.	Entity Name:											
	Contact Name:											
	Contact Tel:											
	Contact Cell:											
	Contact email / other:											
Enter the Client/ Employer's details, OR, if the works was done as a sub-contractor, enter the Main Contractor's Details												

<b>Contract Details</b>	Contract (Reference) Number:										
	Contract Title:										
	Has this Contract been completed?	Y	N	Commencement Date:	d	d	m	m	2	0	y
			Completion Date (if applicable):	d	d	m	m	2	0	y	y
Tendered Value (Contract Sum) OR Sub-Contract Value:	<b>R</b>	Final Contract Price OR Final Value of Sub-Contract:				<b>R</b>					

**Contract Scope-of-Work (Type of Project and Works Elements):**

<b>Which Works Type(s) best describe the project?</b>		Pedestrian Bridge	
Stormwater related structure (culverts etc)		Road Bridge and related structures	
Retaining structures		Maintenance and repairs to structures	
OTHER: provide a description of the type of project			

<b>Which Works Element(s) were included in the project?</b>		Reinforced concrete construction.	
Retaining walls (reinforced concrete, masonry, gabion, proprietary block systems etc).		Reinforced concrete repairs (spalling, member replacement, use of specialist products etc).	
Reinforced and prestressed concrete pedestrian and road bridges.		Specialist proprietary product repair systems or approved product applicator for specific specialist proprietary products.	
Reinforced concrete pedestrian bridges.		Structural steel construction and repairs and application of steel protection systems.	
Structural steel pedestrian bridges.			
OTHER: List works elements included in project			

**Confirmation of documentation submitted is to be recorded on Page 39.**

*I, the undersigned, who warrants that they are authorised to sign on behalf of the Tenderer, confirms that the information contained in this form is within my personal knowledge and is to the best of my belief both true and correct, and that the requested documentation has been included in the tender submission.*

**NAME (Block Capitals):**

**Date**

**SIGNATURE:**

**EXPERIENCE SUBMISSION #4**

Reference is to be made to **Clause F.2.1.3** of the Tender Data.

(Where required, in the shaded areas, clearly mark selection with an "X" or circle applicable)

<b>Experience as a:</b>	Sub-Contractor:		Main Contractor:									
<b>Client/ Employer OR Main Contractor's Details</b>  Should the Employer's reasonable attempts to make contact, to verify the information provided, fail (for whatever reason) this experience submission will be considered invalid.	Entity Name:											
	Contact Name:											
	Contact Tel:				-				-			
	Contact Cell:				-				-			
	Contact email / other:											
Enter the Client/ Employer's details, OR, if the works was done as a sub-contractor, enter the Main Contractor's Details												

<b>Contract Details</b>	Contract (Reference) Number:												
	Contract Title:												
	Has this Contract been completed?	Y	N	Commencement Date:	d	d	m	m	2	0	y	y	
			Completion Date (if applicable):	d	d	m	m	2	0	y	y		
Tendered Value (Contract Sum) OR Sub-Contract Value:	<b>R</b>	Final Contract Price OR Final Value of Sub-Contract:						<b>R</b>					

**Contract Scope-of-Work (Type of Project and Works Elements):**

<b>Which Works Type(s) best describe the project?</b>		Pedestrian Bridge	
Stormwater related structure (culverts etc)		Road Bridge and related structures	
Retaining structures		Maintenance and repairs to structures	
OTHER: provide a description of the type of project			

<b>Which Works Element(s) were included in the project?</b>		Reinforced concrete construction.	
Retaining walls (reinforced concrete, masonry, gabion, proprietary block systems etc).		Reinforced concrete repairs (spalling, member replacement, use of specialist products etc).	
Reinforced and prestressed concrete pedestrian and road bridges.		Specialist proprietary product repair systems or approved product applicator for specific specialist proprietary products.	
Reinforced concrete pedestrian bridges.		Structural steel construction and repairs and application of steel protection systems.	
Structural steel pedestrian bridges.			
OTHER: List works elements included in project			

**Confirmation of documentation submitted is to be recorded on Page 39.**

*I, the undersigned, who warrants that they are authorised to sign on behalf of the Tenderer, confirms that the information contained in this form is within my personal knowledge and is to the best of my belief both true and correct, and that the requested documentation has been included in the tender submission.*

**NAME (Block Capitals):** \_\_\_\_\_

**Date**

**SIGNATURE:** \_\_\_\_\_

**PART C1: AGREEMENT AND CONTRACT DATA**

**C1.1: FORM OF OFFER AND ACCEPTANCE**

**C1.1.1: OFFER**

The Employer, identified in the Acceptance signature block, has solicited offers to enter into a contract in respect of the following works:

Contract No: **1R-27765**

Contract Title: **Routine structural maintenance repairs to municipal owned retaining walls within eThekweni Municipality boundaries for 18 Months**

The Tenderer, identified in the Offer signature block below, has examined the documents listed in the Tender Data and addenda thereto as listed in the Tender Schedules, and by submitting this Offer has accepted the Conditions of Tender.

By the representative of the Tenderer, deemed to be duly authorised, signing this part of this Form of Offer and Acceptance, the Tenderer offers to perform all of the obligations and liabilities of the Contractor under the Contract including compliance with all its terms and conditions according to their true intent and meaning for an amount to be determined in accordance with the Conditions of Contract identified in the Contract Data.

**\* The offered total of the prices inclusive of Value Added Tax is:**

R..... (In words .....  
.....)

This Offer may be accepted by the Employer by signing the Acceptance part of this Form of Offer and Acceptance and returning one copy of this document to the Tenderer before the end of the period of validity stated in the Tender Data, whereupon the Tenderer becomes the party named as the Contractor in the Conditions of Contract identified in the Contract Data.

**For the Tenderer:**

**\* Name of Tenderer** (organisation) : .....

**\* Signature** (of person authorized to sign the tender) : .....

**\* Name** (of signatory in capitals) : .....

**Capacity** (of Signatory) : .....

**Address** : .....  
: .....

**Telephone** : .....

**Witness:**

**Signature** : ..... **Date** : .....

**Name** (in capitals) : : .....

**Notes:**

**\* Indicates what information is mandatory.**

**Failure to complete the mandatory information and sign this form will invalidate the tender.**

**C1.1: FORM OF OFFER AND ACCEPTANCE**

**C1.1.2: FORM OF ACCEPTANCE**

**This Form will be completed by the Employer**

By signing this part of the Form of Offer and Acceptance, the Employer identified below accepts the Tenderer's Offer. In consideration thereof, the Employer shall pay the Contractor the amount due in accordance with the Conditions of Contract identified in the Contract Data. Acceptance of the Tenderer's Offer shall form an agreement between the Employer and the Tenderer upon the terms and conditions contained in this Agreement and in the Contract that is the subject of this Agreement.

The terms of the contract are contained in:

- Part C1 : Agreement and Contract Data, (which includes this Agreement)
- Part C2 : Pricing Data, including the Bill of Quantities
- Part C3 : Scope of Work
- Part C4 : Site Information

and the schedules, forms, drawings and documents or parts thereof, which may be incorporated by reference into Parts C1 to C4 above.

Deviations from and amendments to the documents listed in the Tender Data and any addenda thereto listed in the Tender Schedules as well as any changes to the terms of the Offer agreed by the Tenderer and the Employer during this process of offer and acceptance, are contained in the Schedule of Deviations attached to and forming part of this Agreement. No amendments to or deviations from said documents are valid unless contained in this Schedule, which must be duly signed by the authorised representatives of both parties.

The Tenderer shall within two weeks after receiving a completed copy of this Agreement, including the Schedule of Deviations (if any), contact the Employer's agent (whose details are given in the Contract Data) to arrange the delivery of any bonds, guarantees, proof of insurance and any other documentation to be provided in terms of the Conditions of Contract identified in the Contract Data at, or just after, the date this Agreement comes into effect. Failure to fulfill any of these obligations in accordance with those terms shall constitute a repudiation of this Agreement.

Notwithstanding anything contained herein, this Agreement comes into effect on the date when the Tenderer receives one fully completed original copy of this document, including the Schedule of Deviations (if any). Unless the Tenderer (now Contractor) within five days of the date of such receipt notifies the Employer in writing of any reason why he cannot accept the contents of this Agreement, this Agreement shall constitute a binding contract between the parties.

**Signature** (*person authorized to sign the acceptance*) : .....

**Name** (*of signatory in capitals*) : .....

**Capacity** (*of Signatory*) : .....

**Name of Employer** (*organisation*) : .....

**Address** : .....

: .....

**Witness:**

**Signature** : ..... **Date** : .....

**Name**(*in capitals*) : .....

**C1.1: FORM OF OFFER AND ACCEPTANCE**

**C1.1.3: SCHEDULE OF DEVIATIONS**

**This form will be completed by THE EMPLOYER and ONLY THE SUCCESSFUL TENDERER**

- 1. **Subject** : .....
- Details** : .....
- : .....
- 2. **Subject** : .....
- Details** : .....
- : .....
- 3. **Subject** : .....
- Details** : .....
- : .....

By the duly authorised representatives signing this Schedule of Deviations, the Employer and the Tenderer agree to and accept the foregoing Schedule of Deviations as the only deviations from and amendments to the documents listed in the Tender Data and addenda thereto as listed in the Tender Schedules, as well as any confirmation, clarification or change to the terms of the offer agreed by the Tenderer and the Employer during this process of offer and acceptance.

**FOR THE TENDERER**

**FOR THE EMPLOYER**

.....	Signature	.....
.....	Name ( <i>in capitals</i> )	.....
.....	Capacity	.....
.....	Name and Address of	.....
.....	Organisation	.....
.....		.....
.....	Witness Signature	.....
.....	Witness Name	.....
.....	Date	.....

## C1.2: CONTRACT DATA

### C1.2.1 CONDITIONS OF CONTRACT

#### C1.2.1.1 GENERAL CONDITIONS OF CONTRACT

The Conditions of Contract are the **General Conditions of Contract for Construction Works (2015 3<sup>rd</sup> Edition)**, (**GCC 2015**) published by the South African Institution of Civil Engineering. Copies of these conditions of contract may be obtained from the South African Institution of Civil Engineering (Tel: 011-805-5947, Fax: 011-805-5971, E-mail: [civilinfo@saice.org.za](mailto:civilinfo@saice.org.za)).

The Contract Data (including variations and additions) shall amplify, modify, or supersede, the GCC 2015 to the extent specified below, and shall take precedence and shall govern.

Each item of data given below is cross-referenced to the clause in the GCC 2015 to which it mainly applies.

### C1.2.2 CONTRACT DATA

#### C1.2.2.1 DATA TO BE PROVIDED BY THE EMPLOYER

1.1.1.13 The **Defects Liability Period**, from the date of the Certificate of Completion, is **1 Year**

1.1.1.14 The **time for achieving Practical Completion**, from the Commencement Date is **18 Months**. The period as stated in 5.3.2, and the 7 days referred to in 5.3.3, are included in the above time for achieving Practical Completion. The special non-working days as stated in 5.8.1 are excluded from the above time for achieving Practical Completion.

1.1.1.15 The Employer is the eThekweni Municipality as represented by:  
Deputy Head: **Roads Provision**

1.2.1.2 The address of the Employer is:  
Physical: **Engineering Unit, 166 KE Masinga Road, Durban, 4001**  
Postal: **Engineering Unit, PO Box 680, Durban, 4001**  
Telephone: **031-311-7642 (t)**  
Fax: **Not Applicable**  
E-Mail: **Sandile.Masondo@durban.gov.za**

1.1.1.16 The **name of the Employer's Agent** is: Peter Fenton

1.2.1.2 The address of the Employer' Agent is:  
Physical: **Roads Provision, 30 Archie Gumede Place, Durban, 4001**  
Postal: **Engineering Unit, PO Box 680, Durban, 4001**  
Telephone: **031-311-7671 (t)**  
Fax: **Not Applicable**  
E-Mail: **Peter.Fenton@durban.gov.za**

1.1.1.26 The **Pricing Strategy** is by **Re-measurement Contract**.

3.2.3 The Employer's Agent shall obtain the **specific approval of the Employer** before executing any of his functions or duties according to the following Clauses of the General Conditions of Contract:

- **6.3: Council approval in order to authorise any expenditure in excess of the Tender Sum plus 15% contingencies.**



- 4.11.1 To carry out and complete the works, the Contractor shall employ a competent Site Agent and Foreman as part of the key staff. It is a requirement for the Contractor's Site Agent and Foreman to each have a minimum of 3 years relevant experience including experience on projects of a similar nature. The CV's of the Site Agent and the Foreman should be submitted to the Employer's Agent's Representative for acceptance by the Department (reference is made to Cl.5.3.1 of the Contract Data).

Note:

- i) "similar nature" implies projects that were of a value of at least 70% of this tender's value, and had a comparable Scope of Work in terms of technical requirements and operations.
- ii) "experience" implies experience on projects of a similar nature.
- iii) "accredited degree / diploma" implies a minimum 3-year qualification within the built environment, from a registered University or Institute of Technology.

- 5.3.1 The **documentation required** before commencement with Works execution are:

- **Health and Safety Plan** (refer to Clause 4.3)
- **Initial Programme** (refer to Clause 5.6)
- **Security** (refer to Clause 6.2)
- **Insurance** (refer to Clause 8.6)
- **CV(s) of Key Site Staff** (refer to Clause 4.11.1)

- 5.3.2 The **time to submit the documentation** required before commencement with Works is **14 Days**.

- 5.3.3 Add the following paragraph:

"If a construction work permit, in terms of Clause 3(1) of the Construction Regulations (2014), is applicable, the instruction to commence carrying out of the works may only be issued once the construction work permit has been obtained by the Employer's Agent. If a construction work permit is applicable, the contractor shall allow for a minimum period of 37 days, after the submission (or re-submission) of the documentation referred to in Clause 5.3.1., for the issuing of the construction work permit."

- 5.8.1 The **non-working days** are **Saturdays and Sundays**.

- (5.1.1) The **special non-working days** are:

- All statutory holidays as declared by National or Regional Government.
- The year-end break:
  - Commencing on the first working day after 15 December.
  - Work resumes on the first working day after 5 January of the next year.

- 5.8.1 Delete the words "sunset and sunrise" and replace with "17:00 and 07:00".

- 5.12.2.2 **Abnormal Climatic Conditions (Rain Delays)** - The numbers of days per month, on which work is expected not to be possible as a result of rainfall, for which the Contractor shall make provision, is given in the table below. During the execution of the Works, the Employer's Agent's Representative will certify a day lost due to rainfall only if at least 75% of the work force and plant on site could not work during that specific working day.

Extension of time as a result of rainfall shall be calculated monthly being equal to the number days certified by the Employer's Agent's Representative as lost due to rainfall, less the number of days allowed for as in table below, which could result in a negative figure for certain months. The total extension of time for which the Contractor may apply, shall be the cumulative algebraic sum of the monthly extensions. Should the sum thus obtained be negative, the extension of time shall be taken as NIL.

<u>Month</u>	<u>Days Lost</u>	<u>Average Rainfall</u>	<u>Month</u>	<u>Days Lost</u>	<u>Average Rainfall</u>
January	4*	134	July	1	39
February	3	113	August	2	62
March	3	120	September	2	73
April	2	73	October	3	98
May	2	59	November	3	108
June	1	28	December	1*	102
TOTAL	27	1009mm	* = The number of working days lost allows for the annual statutory Construction holiday in December and January of each year.		

5.13.1 The **penalty for delay** in failing to complete the Works is **R 10,000.00** (per Day).

5.14.1 The **requirements for achieving Practical Completion** will be determined by the Employer's Agent (in consultation with the Contractor) and recorded in the minutes of the first Site Meeting / Handover Meeting. (Refer to 1.1.1.24 for a generic definition.) The requirements are to be regularly reviewed with respect to any variations to the Contract.

5.16.3 The **latent defect liability** period is **10 Years**.

6.2.1 **Security (Performance Guarantee)**: Delete the word "selected" and replace it with "stated".

The liability of the Performance Guarantee shall be as per the following table:

<b>Value of Contract (incl. VAT)</b>	<b>Performance Guarantee Required</b>
Less than or equal to R 1m	Nil
Greater than R 1m and less than or equal to R 10m	5% of the Contract Sum
Greater than R 10m	10% of the Contract Sum

6.5.1.2.3 The **percentage allowance** to cover overhead charges for daywork are as follows:

- **80%** of the gross remuneration of workmen and foremen actually engaged in the daywork;
- **20%** on the net cost of materials actually used in the completed work.

No allowance will be made for work done, or for materials and equipment for which daywork rates have been quoted at tender stage.

6.8.2 **Contract Price Adjustment Factor:** The value of the certificates issued shall be adjusted in accordance with the Contract Price Adjustment Schedule (GCC 2015 - page 86) with the following Indices / Descriptions / Coefficients:

- The proportion not subject to adjustment: **x = 0.10**.
- The base month will be the month prior to the month in which tenders close.
- The Index for Labour, Plant, and Materials shall be based on **December 2021 = 100**.
- The Index for Fuel shall be based on **December 2020 = 100**.

	STATS SA Statistical Release	Table	Description	Coefficient
• "L" is the "Labour Index"	P0141	Table A	Geographic Indices; CPI per Province; Kwa-Zulu Natal	<b>a = 0.28</b>
• "P" is the "Contractor's Equipment Index"	P0151.1	Table 4	Plant and Equipment	<b>b = 0.28</b>
• "M" is the "Materials Index"	P0151.1	Table 6	Civil Engineering Material (excluding bitumen)	<b>c = 0.38</b>
• "F" is the "Fuel Index"	P0142.1	Table 1	Coke, petroleum, chemical, rubber and plastic products; Coal and petroleum products; Diesel	<b>d = 0.06</b>

6.8.3 Price adjustments for **variation in the cost of the special material(s)** listed below, will be allowed.

**Bitumen** - escalation will be calculated using the "Rise and Fall" method as determined by the Employer. The base price for bitumen on this contract shall be the ruling price of 50/70 grade bitumen based on the "Shell Whole Sale List Selling Price for Penetration Grade Bitumen", seven (7) days prior to the closing date of tenders.

6.10.1.5 The **percentage advance** on materials not yet built into the Permanent Works is **80%**.

The **percentage advance** on Plant not yet supplied to Site: **Not Required**

6.10.3 **Retention Money:** Delete the word "selected".

The percentage retention on the amounts due to the Contractor is 10%.

The limit of "retention money" is 5% of the Contract Sum.

Should the Contract Price exceed the Contract Sum then the limit of "retention money" is 5% of the Contract Price.

Interest will not be paid on retention withheld by the Employer.

8.6.1.1.2 The **value of Plant and materials** supplied by the Employer to be included in the insurance sum: **Not Required**.

8.6.1.1.3 The **amount to cover professional fees** for repairing damage and loss to be included in the insurance sum: **Not Required**.

8.6.1.2 **SASRIA Coupon Policy** for Special Risks to be issued in joint names of Council and Contractor for the full value of the works (including VAT).

8.6.1.3 The limit of indemnity for **liability insurance**: **R 10,000,000.00**

8.6.1.4 **Ground Support Insurance:**

- Minimum amount for any one occurrence, unlimited as to the number of occurrences, against any claim for damages or loss caused by vibration and / or removal of lateral support: **R2,000,000.00**
- Maximum first excess: **R 10,000.00**

8.6.1.5 Furthermore, the insurance cover effected by the Contractor shall meet the following requirements:

**Third Party Insurance (Public Liability)**

- Minimum amount for any one occurrence, unlimited as to the number of occurrences, for the period of the contract, inclusive of the maintenance period: **R 5,000,000.00**
- Consequential loss to be covered by policy: **Yes**
- Liability section of policy to be extended to cover blasting: **Nil**
- Maximum excess per claim or series of claims arising out of any one occurrence: **R 10,000.00**

**Principal's own surrounding Property Insurance**

- Minimum amount for any one occurrence unlimited as to the number of occurrences against any claim for damage which may occur to the Council's own surrounding property: **R1,000,000.00**
- Maximum first excess: **R 5,000.00**

**Insurance of Works**

- Minimum amount for additional removal of debris (no damage): **Nil**
- Minimum amount for temporary storage of materials off site, excluding Contractor's own premises: **Nil**
- Minimum amount for transit of materials to site: **Nil**

8.6.5 **Approval by Employer:** At the end of the sub-clause, add the following paragraph:

"Except where otherwise provided in the Special Conditions of Contract, the insurance cover effected by the Contractor in terms of this clause shall not carry a first loss amount greater than those set out below:

<b>Contract Price</b>	<b>First Loss</b>
Less than R 100,000	R 5,000
R 100,000 to R 500,000	R 10,000
R 500,000 to R 1,000,000	R 20,000
R 1,000,000 to R 2,000,000	R 30,000
R 2,000,000 to R 4,000,000	R 40,000
Greater than R 4,000,000	R 50,000

The insurance policy shall contain a specific provision whereby cancellation of the policy prior to the end of the period referred to in Cause 8.2.1 cannot take place without the prior written approval of the Employer."

10.7.1 **Failing ad-hoc adjudication, the determination of disputes shall be by arbitration.**

**C1.2.2.2 DATA TO BE PROVIDED BY CONTRACTOR**

1.1.1.9 The legal name of Contractor is:

.....  
.....  
.....  
.....

1.2.1.2 The Physical address of the Contractor is:

.....  
.....  
.....  
.....

The Postal address of the Contractor is:

.....  
.....  
.....  
.....

The contact numbers of the Contractor are:

Telephone: .....

Fax: .....

The E-Mail address of the Contractor is:

.....

## C1.2.3 ADDITIONAL CONDITIONS OF CONTRACT

### C1.2.3.1 COMMUNITY LIAISON OFFICER

The Ward Councillor(s) in whose ward(s) work is to be done will, collectively, identify a community liaison officer (CLO) for the project and make the person known to the Contractor within two days of being requested to do so. The Contractor will be required to enter a written contract with the CLO that specifies:

- The hours of work and the wage rate of the CLO (200% of the Civil Engineering Industry minimum wage).
- The duration of the appointment.
- The duties to be undertaken by the CLO which could include:
  - Assisting in all respects relating to the recruitment of local labour.
  - Acting as a source of information for the community and councillors on issues related to the contract.
  - Keeping the Contractor advised on community issues and issues pertaining to local security.
  - Assisting in setting up any meetings or negotiations with affected parties.
  - Keeping a written record of any labour or community issue that may arise.
  - Any other duties that may be required by the Contractor.

Responsibility for the identification of a pool of suitable labour shall rest with the CLO, although the Contractor shall have the right to choose from that pool. The Contractor shall have the right to determine the total number labourers required at any one time and this may vary during the contract.

The Contractor shall have the right to replace labour that is not performing adequately. Should such occasion arise, it must be done in conjunction with the CLO.

**Payment: The CLO will be reimbursed from the PC Sum item in the Preliminary & General Section of the Bill of Quantities.**

### C1.2.3.2 EMPLOYMENT OF LOCAL LABOUR

It is a condition of contract that the contractor will be required to employ local labour as specified in eThekweni Council Policy "The use of CLOs and Local Labour". The contractor will be required to ensure that a minimum of 50% of the labour force is made up of local labour. For the purposes of this contract, "Local labour" will be deemed to be any persons **who reside within the eThekweni Metropolitan area**. The contractor will be required to provide proof of authenticity of local labour. Signed confirmation by the appointed CLO will suffice for this.

No additional costs will be entertained due to this Particular Specification. The contractor will remain responsible for providing proper supervision of all labour and will be responsible for the quality of work produced.

### C1.2.3.3 CONTRACTOR PARTICIPATION GOAL (CPG)

It is a condition of contract that the contractor must allow for a minimum of **5%** of the contract value (excluding PC Sum items and Fixed Cost allowances) to be subcontracted to contractors who are **>51% black** owned. Proof of payment to the subcontractors will be required to verify that the minimum has been achieved.

The penalty for not achieving the specified CPG will be 0.5% of the contract value (excluding PC Sum items and Fixed Cost allowances) for every 1% of CPG not achieved.

**C1.2.3.4 FTE (Full Time Equivalent) EMPLOYMENT INFORMATION**

It is a condition of contract that the Contractor supplies the Employer’s Agent’s Representative with information in respect of the employment of all foremen, artisans and labour (skilled and unskilled) employed to work on this contract. The information required is:

- Initials (per ID doc)
- Last Name (per ID doc)
- ID Number
- Disability (y / n)
- Education Level

<b>Level 1</b> Unknown	<b>Level 2</b> No Schooling	<b>Level 3</b> Grade 1-3	<b>Level 4</b> Grade 4	<b>Level 5</b> Grade 5-6
<b>Level 6</b> Grade 7-8	<b>Level 7</b> Grade 9	<b>Level 8</b> Grade 10-11	<b>Level 9</b> Grade 12	<b>Level 10</b> Post Matric

- Category of Employment

<b>Category A:</b> Employed as Local Labour for this contract only <b>Category B:</b> Temporarily employed by the Contractor <b>Category C:</b> Permanently employed by the Contractor
--

In addition, the following information is required in respect of each person listed above, on a monthly basis:

- Number of days worked during the month;
- Daily wage rate;
- Number of training days during the month.

The information is to be forwarded in a format acceptable to the Employer’s Agent’s Representative, but preferably in the form of an emailed EXCEL file (an original file, to be used as a template, will be issued to the Contractor). Contractors without computer facilities will be required to submit a hard copy of the information in a format as agreed to between the Contractor and the Employer’s Agent’s Representative.

In addition to the tax invoice, to be submitted by the Contractor with his monthly statement, mentioned in Clause 6.10.4 of GCC 2015, the Employer reserves the right to withhold payment until the monthly FTE information has been forwarded to the Employer’s Agent’s Representative. No additional payment for complying with the above will be made and the Contractor is to make allowance for complying through the time related P & G items (sum) under Part AA: Preliminaries, of the Bill of Quantities.

**C1.2.3.5 PERFORMANCE MONITORING OF SERVICE PROVIDERS**

[For contract awards over R10m] The Contractor shall be subjected to “Performance Monitoring” assessments in terms of the applicable Section (S.53) of the Employer’s Supply Chain Management Policy.

Key Performance Indicators (KPIs) are specified in the C3: Scope of Works, or will be discussed and agreed with the Contractor before commencement of the contract.

**C1.2.3.6 EXCEPTED RISKS (Clause 8.3)**

Pursuant to Clause 8.3 of the Conditions of Contract (GCC 2015), the Employer shall not be liable for the payment of standing time costs as a result of the occurrence of any of the “Excepted Risks” as defined under Clause 8.3.

However, the Employer shall reimburse the Contractor in respect of plant de-establishment and re-establishment costs as a result of “Excepted risks” when a written instruction to de-establish is issued to the Contractor.

## C2.1: PRICING ASSUMPTIONS / INSTRUCTIONS

### C2.1.1 GENERAL

The Bill of Quantities forms part of the Contract Documents and must be read and priced in conjunction with all the other documents comprising the Contract Documents (refer to F.1.2 of the Tender Data).

### C2.1.2 PRICING INSTRUCTIONS AND DESCRIPTION OF ITEMS IN THE SCHEDULE

Measurement and payment shall be in accordance with the relevant provisions of Part C of each of the Standard Specifications referred to in the Scope of Work. The Preliminary and General items shall be measured in accordance with the provisions of C2.1.8.

The descriptions of the items in the Bill of Quantities are for identification purposes only and comply generally with those in the Standard Engineering Specification.

Clause C of each Standard Specification, read together with the relevant clauses of the Scope of the works, set out what ancillary or associated work and activities are included in the rates for the operations specified. Should any requirements of the measurement and payment clause of the applicable Standard Specification, or the Scope of the works, conflict with the Bill of Quantities, the requirements of the Standard Specification or Scope of the work, as applicable, shall prevail.

### C2.1.3 QUANTITIES REFLECTED IN THE SCHEDULE

The quantities given in the Bill of Quantities are estimates only, and subject to re-measuring during the execution of the work. The Contractor shall obtain the Employer's Agent's detailed instructions for all work before ordering any materials or executing work or making arrangements for it.

The Works as finally completed in accordance with the Contract shall be measured and paid for as specified in the Bill of Quantities and in accordance with the General and Special Conditions of Contract, the Specifications and Project Specifications and the Drawings. Unless otherwise stated, items are measured net in accordance with the Drawings, and no allowance

has been made for waste.

The validity of the contract will in no way be affected by differences between the quantities in the Bill of Quantities and the quantities finally certified for payment.

### C2.1.5 MONTHLY PAYMENTS

Unless otherwise specified in the Specifications and Project Specifications, progress payments in Interim Certificates, referred to in Clause 6.10.1 of the General Conditions of Contract, in respect of "sum" items in the Bill of Quantities shall be by means of interim progress instalments assessed by the Employer's Agent and based on the measure in which the work actually carried out relates to the extent of the work to be done by the Contractor.

### C2.1.4 PROVISIONAL SUMS / PRIME COST SUMS

Where Provisional Sums or Prime Cost sums (PC Sum) are provided for items in the Bill of Quantities, payment for the work done under such items will be made in accordance with Clause 6.6 of the General Conditions of Contract. The Employer reserves the right, during the execution of the works, to adjust the stated amounts upwards or downwards according to the work actually done under the item, or the item may be omitted altogether, without affecting the validity of the Contract.

The Tenderer shall not under any circumstances whatsoever delete or amend any of the sums inserted in the "Amount" column of the Bill of Quantities and in the Summary of the Bill of Quantities unless ordered or authorized in writing by the Employer before closure of tenders. Any unauthorized changes made by the Tenderer to provisional items in the schedule, or to the provisional percentages and sums in the Summary of the Bill of Quantities, will be treated as arithmetical errors.

### C2.1.6 PRICING OF THE BILL OF QUANTITIES

The prices and rates to be inserted by the Tenderer in the Bill of Quantities shall be the full inclusive prices to be paid by the Employer for the work described under the several items, and shall include full compensation



for all costs and expenses that may be required in and for the completion and maintenance during the defects liability period of all the work described and as shown on the drawings as well as all overheads, profits, incidentals and the cost of all general risks, liabilities and obligations set forth or implied in the documents on which the Tender is based.

Each item shall be priced and extended to the "Total" column by the Tenderer, with the exception of the items for which only rates are required (Rate Only), or items which already have Prime Cost or Provisional Sums affixed thereto. If the Contractor omits to price any items in the Bill of Quantities, then these items will be considered to have a nil rate or price.

All items for which terminology such as "inclusive" or "not applicable" have been added by the Tenderer will be regarded as having a nil rate which shall be valid irrespective of any change in quantities during the execution of the Contract.

All rates and amounts quoted in the Bill of Quantities shall be in Rands and Cents and shall include all levies and taxes (other than VAT). VAT will be added in the Summary of the Bill of Quantities.

#### **C2.1.7 "RATE ONLY" ITEMS**

The Tenderer shall fill in rates for all items where the words "Rate Only" appear in the "Total" column. "Rate Only" items have been included where:

- (a) an alternative item or material is contemplated;
- (b) variations of specified components in the make-up of a pay item may be expected; and
- (c) no work under the item is foreseen at tender stage but the possibility that such work may be required is not excluded.

For "Rate Only" items no quantities are given in the "Quantity" column but the quoted rate shall apply in the event of work under this item being required. The Tenderer shall however note that in terms of the Tender Data the Tenderer may be asked to reconsider any such rates which the Employer may regard as unbalanced.

#### **C2.1.8 PRELIMINARY AND GENERAL**

The Preliminary and General Section is provided to cover the Contractor's expenses incurred in complying

with the requirements of the tender documents and consists of the following parts:

- Part 0102: General Requirements and Provisions
- Part 0103: Contractor's Site Establishment
- Part 0104: Facilities for Engineer
- Part 0105: Accommodation of Traffic

**Fixed Charge Items:** Each item should be priced separately and, subject to the Engineer certifying in terms of [Clause 6.7 of the General Conditions of Contract](#) that the work has been done, payment will be made as follows:

- (i) the total amount due when the certified value fixed charge items in this section is less than 5% of the net contract price;
- (ii) when the certified value of fixed charge items in this section is greater than 5% of the net contract price, payment will be limited to 5% of the net contract price. The remainder will be paid when the value of the work done under the contract, excluding the value of fixed charge items in this section, is greater than 50% of the net contract price, excluding the value of fixed charge items in this section.

**Time Related Items:** Any Time Related items not priced shall be deemed to be covered by the prices of other items in the section.

Payment of Time Related items in this section will be made throughout the contract period, the amount per month being the value of the item divided by the completion in months or, if specified in weeks, the equivalent number of months, in terms of [Clause 5.5 of the General Conditions of Contract](#). The final monthly increment will only be paid upon the issue of a completion certificate.

**Value Related Items:** Any Value Related items not priced shall be deemed to be covered by the prices of other items in the section.

Payment of Value Related items in this section will be made throughout the contract period, the amount per month being calculated using the percentage of the works done and tendered price. The final monthly increment will only be paid upon the issue of a completion certificate. The adjusted lump sum will be the full settlement of any difference in value-related general obligations resulting from an increase or decrease in value of the work.

**C2.2: BILL OF QUANTITIES**

The Bill of Quantities follows and comprises of 13 pages. The pages are numbered [C2.1](#) to [C2.10](#)

**PART C3: SCOPE OF WORK**

	<b><u>PAGE</u></b>
<b>C3.1 PROJECT DESCRIPTION AND SCOPE OF CONTRACT</b>	<b>59</b>
<b>C3.2 PROJECT SPECIFICATIONS</b>	<b>60</b>
PS.1 Programme, Method of Work, and Accommodation of Traffic	
PS.2 Services	
PS.3 Watermains	
PS.4 Sewers	
PS.5 Stormwater	
PS.6 Electrical Plant	
PS.7 Telkom S.A. Limited / Neotel Plant	
PS.8 CCTV Plant	
PS.9 Management of the Environment	
PS.10 Occupational Health and Safety	
<b>C3.3 STANDARD SPECIFICATIONS</b>	<b>70</b>
C3.3.1 Listing of the Standard Specifications	
C3.3.2 Amendments to the Standard Specifications	
<b>C3.4 PARTICULAR SPECIFICATIONS</b>	<b>85</b>
C3.4.1 Part AH - OHS Act 1993 Safety Specification (2014)	
C3.4.2 Standard Environmental Management Plan for Civil Engineering Construction Works	
<b>C3.5 CONTRACT AND STANDARD DRAWINGS</b>	<b>86</b>
C3.5.1 Contract Drawings / Details	
C3.5.2 Standard Drawings	
<b>C3.6 ANNEXURES</b>	<b>87</b>

---

### **C3.1: PROJECT DESCRIPTION AND SCOPE OF CONTRACT**

#### **C3.1.1 Description of Works**

This contract calls for routine maintenance of all retaining walls located within the eThekweni Metropolitan area. The list of retaining walls will be issued upon award of tender.

Repair works measures:

- a) Preliminary and general requirements.
- b) Access scaffolding with working platforms fully protected with shutter board.
- c) Accommodation of traffic;
  - a. Rail – In accordance with the rail authority specification SPK7/1.
  - b. Road deviations and appropriate signage
  - c. Pedestrian traffic accommodation.
- d) Supply, preparations and application of non-shrink epoxy grout crack sealing into cracks.
- e) Clearing of overgrown vegetation including, but not limited to, grubbing of trees and poisoning the roots with a herbicide such as Two-Step SC or similar approved, removal of refuse, litter, and sand present within the retaining wall structure to an approved tip site.
- f) Repair concrete spalling.
- g) Repair surfaces of reinforced wall structures.
- h) Removal and replacement of precast members and elements on retaining wall structures.
- i) Cleaning and painting of steel and concrete wall structures.
- j) Repair damaged guardrails as and when directed.
- k) Repair and restore damaged handrailing systems to match retaining walls.
- l) Supply, install and compact earthworks adjacent retaining walls.
- m) Replace damaged masonry blocks on retaining wall structure.
- n) Repair and clean any drainage systems to retaining walls.

#### **C3.1.2 Description of Site and Access**

The sites are located within eThekweni Metropolitan area.

#### **C3.1.3 Nature of Ground and Subsoil Conditions**

The sites are located within eThekweni Metropolitan area.

---

## **C3.2: PROJECT SPECIFICATION**

### **PREAMBLE**

In the event of any discrepancy between a part or parts of the Standard or Particular Specifications and the Project Specification, the Project Specification shall take precedence. In the event of a discrepancy between the Specifications, (including the Project Specifications) and the drawings and / or the Bill of Quantities, the discrepancy shall be resolved by the Employer's Agent before the execution of the work under the relevant item.

### **C3.2.1 GENERAL**

#### **PS.1 PROGRAMME, METHOD OF WORK, AND ACCOMMODATION OF TRAFFIC**

This Clause is to be read in conjunction with the provisions and obligations as contained in [SANS 1921-1](#) and [SANS 1921-2](#).

##### **PS.1.1 Preliminary Programme**

The Contractor shall submit a scheme 1 preliminary programme prior works commencement. The programme shall be in the form of a simplified bar chart with sufficient details to show clearly how the works will be performed within the time for completion as stated in the Contract Data.

Tenderers may submit tenders for an alternative Time for Completion in addition to a tender based on the specified Time for Completion. Each such alternative tender shall include a preliminary programme similar to the programme above for the execution of the works, and shall motivate his proposal clearly by stating all the financial implications of the alternative completion time.

The Contractor shall be deemed to have allowed fully in his tendered rates and prices as well as in his programme for all possible delays due to normal adverse [weather conditions \(refer to Clause 5.12.2.2\)](#) and special non-working days ([refer to Clause 5.1.1.1](#)) as specified in the in the Contract Data.

##### **PS.1.2 Programme in Terms of Clause 5.6 of the General Conditions of Contract**

It is essential that the construction programme, which shall conform in all respects to [Clause 5.6 of the General Conditions of Contract](#), be furnished within the time stated in the Contract Data ([refer to Clause 5.3.1/2](#)).

The preliminary programme to be submitted with returnable documents shall be used as basis for this programme.

Those known, existing services in the area of the works have been depicted on the contract drawings. It is evident, however, that the status of existing service records as far as can be ascertained might not reflect the actual situation in the field. As such, due allowance has been made in the Bill of Quantities for the proving of services where directed by the Engineer.

---

**PS.1.3 Requirements for Accommodation of Traffic****PS.1.3.1 General**

Accommodation of traffic, where applicable, shall comply with [SANS 1921-2: 2004: Construction and Management Requirements for Works Contracts, Part 2: Accommodation of Traffic on Public Roads occupied by the Contractor, COTO \(2020\): Part 0105 – Accommodation of traffic](#). The Contractor shall obtain this specification from Standards South Africa if accommodation of traffic will be involved on any part of the construction works.

[Clause 4.10.4 of SANS 1921-2: 2004](#) shall be replaced with the following:

“Road signs and markings shall comply with the requirements of the [“SADC Road Traffic Signs Manual - Volume 2: Roadworks Signing”](#).”

**PS.1.3.2 Basic Requirements**

The travelling public shall have the right of way on public roads, and the Contractor shall make use of approved methods to control the movement of his equipment and vehicles so as not to constitute a hazard on the road.

The Contractor shall ensure that all road signs, barricades, delineators, flagmen and speed controls are effective, and that courtesy is extended to the public at all times.

Failure to maintain road signs, warning signs or flicker lights, etc, in a good condition shall constitute ample reason for the Employer’s Agent to suspend the work until the road signs, etc, have been repaired to his satisfaction.

The Contractor may not commence constructional activities affecting existing roads before adequate provision has been made to accommodate traffic in accordance with the requirements of this document and the South African Road Traffic Signs Manual.

The Contractor shall construct and maintain all temporary drainage works necessary for temporary deviations. The Contractor shall ensure that the existing property accesses are maintained at all times. Where necessary the Contractor shall make allowance in the rates for completing the work required to the accesses out of normal hours.

**PS.1.3.3 Traffic Safety Officer**

Where warranted by traffic conditions on or near the site, the Contractor shall nominate a suitable member of his staff as traffic safety officer to be responsible for the arrangement and maintenance of all the measures for the accommodation of traffic for the duration of the project. Duties of the traffic safety officer shall be in compliance with the Occupational Health and Safety Act 1993 and the Construction Regulations 2014.

**PS.1.3.4 Payment**

The Contractor’s tendered rates for the relevant items in the Bill of Quantities shall include full compensation for all possible additional costs which may arise from this, and no claims for extra payment due to inconvenience as a result of the modus operandi will be considered.

**PS.1.3.5 Pedestrian Movement**

The Contractor shall make provision for accommodating all pedestrian movements in the area of the works. Allowance shall be made in the relevant rates for any barricades and signs required.

**PS.1.3.6 Temporary Reinstatement**

Provided always that if in the course or for the purpose of the execution of the works or any part thereof any road or way shall have been broken up, then notwithstanding anything herein contained:

- (a) if the permanent reinstatement of such road or way is to be carried out by the appropriate authority or by some person other than the contractor (or any subcontractor to him), the contractor shall at his own cost and independently of any requirement of or notice from the Engineer be responsible for the making good of any subsidence or shrinkage or other defect, imperfection or fault in the temporary reinstatement of such road or way, and for the execution of any necessary repair or amendment thereof from whatever cause the necessity arises, until the end of the period of maintenance in respect of works beneath such road or way until the authority or other person as aforesaid shall have taken possession of the site for the purpose of carrying out permanent reinstatement (whichever is the earlier), and shall indemnify and save harmless that Council against and from any damage or injury to the Council or to third parties arising out of or in consequence of any neglect or failure of the Contractor to comply with the foregoing obligations or any of them and against and from all claims, demands, proceedings, damages, costs, charges and expenses whatsoever in respect thereof or in relation thereto.
- (b) where the authority or person as aforesaid shall take possession of the site as aforesaid in sections or lengths, the responsibility of the contractor under paragraph (a) of this sub-clause shall cease in regard to any such section or length at the time possession thereof is so taken, but shall during the continuance of the said period of maintenance continue in regard to any length of which possession has not been taken and the indemnity given by the contractor under the said paragraph shall be construed and have effect accordingly.

**PS.2 SERVICES**

This Clause is to be read in conjunction with the provisions and obligations as contained in **SANS 1921-1 and SANS 1921-2**.

**PS.2.1 Existing Services**

No work to existing services is envisaged.

**PS.2.2 Proving Underground Services**

This clause must be read in conjunction with **Clause A2.1.3.2**, the requirements of which shall be extended to cover all earthworks operations whether for trenching or bulk earthworks, in the vicinity of underground services.

It is stressed that all services in a particular area must be proven before commencing work in that area.

Insofar as bulk earthworks are concerned, where services are indicated on the drawings or where from site observations can reasonably be expected that such services are likely to exist where excavations are to take place, the Contractor shall without instructions from the Employer's Agent carefully excavate by hand to expose and prove their positions.

The cost of the proving trenches is to be included in the work covered by [Clause C2.1.2](#).

When a service is not located in its expected position the Contractor shall immediately report such circumstances to the Employer's Agent who will decide what further searching or other necessary action is to be carried out and shall instruct the Contractor accordingly. The cost of this additional searching shall be to the Council's cost and shall be paid for under [C2.1.2 – Existing services location, detection, and verification](#).

Should any service be damaged by the Contractor in carrying out the works and should it be found that the procedure as laid down in this clause has not been followed then all costs in connection with the repair of the service will be to the Contractor's account.

When electrical cables are not in the positions shown on drawings of eThekweni Electricity and cannot be found after proving trenches have been put down, assistance may be obtained by calling an official of the [Works Branch on Telephone No. 311-1111](#) during office hours, or by contacting [Control on Telephone No. 305-7171](#) after hours.

It should be noted that 33,000 Volt and 132,000 Volt cables may only be exposed by the eThekweni Electricity's personnel. The cables are usually protected by concrete covering slabs, and therefore if the slabs are inadvertently exposed, excavation work must stop, and the eThekweni Electricity shall be contacted immediately on the above telephone numbers.

Proving of services shall be completed at least two weeks in advance of the actual programmed date for commencing work in the area. The position of these services located must be co-ordinated and levelled by the Contractor, and the information given in writing to the Employer's Agent's Representative.

The requirements of this clause do not relieve the Contractor of any obligations as detailed in the Conditions of Contract or under [Clause 4.17 of SANS 1921-1](#).

### **PS.2.3 New Services and Relocation of Existing**

This clause shall be read in conjunction with [Clause PS.1](#).

New services are either to be installed by the Contractor as part of the contract or by others during the contract period. In the latter case excavation and subsequent backfilling of the trench from the top of the bedding layer shall generally be carried out by the Contractor.

Relocation of services shall generally be carried out by the relevant services organisation. Generally their work shall include the excavating and bedding the service which will include backfilling to a depth of approximately 300 mm above the service. The remainder of the backfilling shall be carried out by the Contractor.

Generally work shall only commence on the installation of new services once the bulk earthworks have been completed and roughly trimmed to level along a substantial portion of the services



route. In addition no sidewalk, verge, median or island shall be surfaced or topsoiled until all work on the services has been completed.

Services affected by the contract are described as follows:

- **PS.3: Watermains;**
- **PS.4: Sewers;**
- **PS.5: Stormwater;**
- **PS.6: Electrical Cables / Lighting;**
- **PS.7: Telkom / Neotel;**
- **PS.8: CCTV;**

Further to the above, tenderers are referred to the services drawing and are to note that several minor cables / pipes may be encountered during excavation works which may require to be relocated to some extent. It is anticipated that the two week period required under **PS.2.2** will allow sufficient time for these relocations.

#### **PS.2.4 Accommodation of Services**

Further to **Clauses PS.1 and PS.2** of this specification, tenderers are to note that allowance must be made under this item and / or the appropriate rates, for all costs incurred as a result of complying with these clauses. It shall also cover liaison with the services organisations and accommodation of their work gangs / contractors on site.

### **PS.3 WATERMAINS**

#### **PS.3.1 General**

**No work to watermains is envisaged.**

#### **PS.3.2 Water Main Valve Access**

Due to the dangerous situation occurring when water main valves are covered over, the Contractor shall maintain access to all water main valves at all times. During asphalt layer work, after each pass by the paving machine, the valves shall be exposed and access maintained in a safe condition.

Whatever method the Contractor chooses to use for this work, the cost of raising the valves from existing level to ultimate level shall be paid only once, irrespective of the number of times the valve is uncovered. Spacer rings required for the height adjustment of valve covers shall be supplied by the Water and Sanitation Unit. Tolerances on valve cover levels shall be as specified in clause PH.6.5. Before final setting in position of valve covers the Contractor shall liaise with the Employer's Agent regarding the direction in which covers shall be placed.

#### **PS.3.3 Restriction on Compactive Equipment**

The Contractor is to note that existing watermains traverse the site of the works and special care is to be taken in close proximity to these mains and connections. The existing mains and connections shall be proved on site by the Contractor prior to any construction work commencing in the vicinity of the watermains.

Under no circumstances will heavy road-making equipment, other heavy plant or vibratory compaction equipment be permitted to operate within 800 mm vertically or horizontally of the existing mains or connections. The permissible compaction plant within this restricted area shall be the equivalent of a "Bomag 90" under static compaction, or similar approved plant. When the roadworks are far enough advanced to provide a minimum of 800 mm cover to the existing mains, the above restriction will fall away.

The Contractor is to take cognisance of the above requirements when entering rates in the Bill of Quantities and in the programming of the works. No claim for additional payment based on the inability to use plant as a result of the requirements of this clause will be accepted. The Contractor will be held liable for any costs should the watermain or electrical cables be damaged during construction of the road.

#### **PS.4 SEWERS**

No work to sewers is envisaged.

##### **PS.4.1 Blockage of Foul Water Sewers**

The Contractor shall be responsible for ensuring that cementitious sludge, sand and rubble from the works do not enter the foul water reticulation system. The Contractor shall be liable for any costs incurred by the Council or others as a result of blockages in the reticulation system attributed to failure to comply with the above requirement.

#### **PS.5 STORMWATER**

No work to stormwater is envisaged. The Contractor shall make provisions should work on retaining walls encompassing stormwater mains be encountered.

##### **PS.5.1 Blockage Stormwater Sewers**

The Contractor shall be responsible for ensuring that cementitious sludge, sand and rubble from the works do not enter the stormwater reticulation system. The Contractor shall be liable for any costs incurred by the Council or others as a result of blockages in the reticulation system attributed to failure to comply with the above requirement.

#### **PS.6 ELECTRICAL PLANT**

No work to electrical plant is envisaged.

##### **PS.6.1 General**

Various types of electrical cables including high voltage, low voltage, street lighting and domestic connection cables are affected by the contract. The laying, relocation and jointing of all cables will be carried out by eThekweni Electricity's work gangs, or agents appointed by them, whilst the excavation and backfilling forms part of this contract. Close liaison will therefore be necessary with eThekweni Electricity throughout the contract.

**PS.6.2 Street Lighting**

The existing lighting will be removed in stages and replaced in the centre median / intersection corners. Relocation will take place during this contract and be executed by eThekweni Electricity or their agents. It is a requirement that the street lighting be operational at all times.

**PS.6.3 MV / LV Cables**

Certain MV / LV cables are to be replaced within the contract area (see drg xxxxxxxxA0). The actual cable work associated with this relocation and / or replacement of these cables will be carried out by eThekweni Electricity and it is stressed that the **two** week period referred to in Clause PS.2 is the minimum period required to enable eThekweni Electricity to be on site timeously.

**PS.6.4 Relocation of Existing Services**

Should it be necessary to adjust the line, level and / or position of any service not catered for in the contract to enable the construction to proceed the Contractor shall on no account effect such adjustment himself but shall notify the Engineer who will arrange for the work to be carried out at no cost to the Contractor.

**PS.7 TELKOM S.A. LIMITED / NEOTEL PLANT**

No work to Telkom / Neotel Plant is envisaged, but the tenderers attention is drawn to the fact that Telkom / Neotel copper cables and fibre optic cables are existing in the contract area.

**PS.8 CCTV PLANT**

No work to CCTV Plant is envisaged, but the tenderers attention is drawn to the fact that CCTV cables and fibre optic cables are existing in the contract area.

**PS.9 MANAGEMENT OF THE ENVIRONMENT**

The Contractor shall pay special attention to the following:

**PS.9.1 Natural Vegetation**

The Contractor shall confine his operation to as small an area of the site as may be practical for the purpose of constructing the works.

Only those trees and shrubs directly affected by the works and such others as the Employer's Agent may direct in writing shall be cut down and stumped. The natural vegetation, grassing and other plants shall not be disturbed other than in areas where it is essential for the execution of the work or where directed by the Engineer.

**PS.9.2 Fires**

The Contractor shall comply with the statutory and local fire regulations. He shall also take all necessary precautions to prevent any fires. In the event of fire the Contractor shall take active steps to limit and extinguish the fire and shall accept full responsibility for damages and claims resulting from such fires which may have been caused by him or his employees.

**PS.9.3 Environmental Management Plan**

In addition to the above, all requirements according to the Environmental Management Plan as detailed in **C3.4: Particular Specifications**, will be adhered to.

**PS.10 OCCUPATIONAL HEALTH AND SAFETY****PS.10.1 General Statement**

When considering the safety on site the Contractor's attention is drawn to the following:

It is a requirement of this contract that the Contractor shall provide a safe and healthy working environment and to direct all his activities in such a manner that his employees and any other persons, who may be directly affected by his activities, are not exposed to hazards to their health and safety. To this end the Contractor shall assume full responsibility to conform to all the provisions of the Occupational Health and Safety Act No 85 and Amendment Act No 181 of 1993, and the OHS Act 1993 Construction Regulations 2014 issued on 7 February 2014 by the Department of Labour.

For the purpose of this contract the Contractor is required to confirm his status as mandatory and employer in his own right for the execution of the contract by entering into an agreement with the Employer in terms of Section 37(2) of the Occupational Health and Safety Act.

**PS.10.2 Health and Safety Specifications and Plans to be submitted at tender stage****PS.10.2.1 Employer's Health and Safety Specification**

The Employer's Health and Safety Specification is included in **C3.4: Particular Specifications**.

**PS.10.2.2 Tenderer's Health and Safety Plan**

At tender stage only a brief overview of the tenderers perception on the safety requirements for this contract will be adequate. This will be attached to **T2.2: Contractor's Health and Safety Plan**.

Only the successful Tenderer shall submit a separate Health and Safety Plan as required in terms of Regulation 7 of the Occupational Health and Safety Act 1993 Construction Regulations 2014, and referred to in **T2.2: Contractor's Health and Safety Plan**.

The detailed safety plan will take into consideration the **site specific risks as mentioned under PS.10.1** and must cover at least the following:

- (i) A proper risk assessment of the works, risk items, work methods and procedures in terms of Regulations 9 to 29;
- (ii) Pro-active identification of potential hazards and unsafe working conditions;
- (iii) Provision of a safe working environment and equipment;
- (iv) Statements of methods to ensure the health and safety of subcontractors, employees and visitors to the site, including safety training in hazards and risk areas (*Regulation 7*);
- (v) Monitoring health and safety on the site of works on a regular basis, and keeping of records and registers as provided for in the Construction Regulations;
- (vi) Details of the Construction Supervisor, the Construction Safety Officers and other

- competent persons he intends to appoint for the construction works in terms of Regulation 8 and other applicable regulations; and
- (vii) Details of methods to ensure that his Health and Safety Plan is carried out effectively in accordance with the Construction Regulations 2014.

The Contractor's Health and Safety Plan will be subject to approval by the Employer, or amendment if necessary, before commencement of construction work. The Contractor will not be allowed to commence work, or his work will be suspended if he had already commenced work, before he has obtained the Employer's written approval of his Health and Safety Plan.

Time lost due to delayed commencement or suspension of the work as a result of the Contractor's failure to obtain approval for his safety plan, shall not be used as a reason to claim for extension of time or standing time and related costs

A generic plan will not be acceptable.

### **PS.10.3 Cost of compliance with the OHSA Construction Regulations**

The rates and prices tendered by the Contractor shall be deemed to include all costs for conforming to the requirements of the Act, the Construction Regulations and the Employer's Health and Safety Specification as applicable to this contract. Should the Contractor fail to comply with the provisions of the Construction Regulations, he will be liable for penalties as provided in the Construction Regulations and in the Employer's Health and Safety Specification.

Items that may qualify for remuneration will be specified in the Employer's Health and Safety Specification.

### **PS.11 SITE SECURITY**

The Contractor shall, for the duration of the contract, provide sufficient security and watchmen to adequately ensure the safety and protection of the works, the Contractor's staff, including local labour and subcontractors, and all site plant and construction equipment required for the works.

Site Security, in conjunction with the SAPS (where necessary), shall be responsible for removal of disruptive elements, that may interrupt the progress of the contract through acts such as, but not limited to, intimidation, threats of disruption, violent disruption, or criminal and illegal activity by the local community or independent organisations or entities that may result in slowing down or partial or total stoppage of the works.

Payment for this item shall be made under Section 1, Part AB of the Bill of Quantities.

### **PS.12 PERFORMANCE MONITORING OF SERVICE PROVIDERS**

The performance of service providers that have been selected to provide assistance in the provision of a municipal service, otherwise than in circumstances where Chapter 8 of the Municipal Systems Act applies, is required, by Section 116 of the Municipal Finance Management Act, to be monitored and reported on (see Cl.53 of the SCM Policy).

Appropriate key performance indicators (KPIs) for the contract must be set by the Municipality as a yardstick for measuring performance.

The following KPIs will be applicable to this contract:

- (a) Adherence to contractual timeframes
- (b) Adherence to specifications and quality control
- (c) Compliance with instructions and site management
- (d) Cashflow and cost management
- (e) OHS matters and environmental management.

**C3.3: STANDARD SPECIFICATIONS**

**C3.3.1** The Specifications on which this contract is based are the [Committee of Transport Officials Standard Engineering Specifications for road and bridgeworks for South African road Authorities – Draft Standard \(Hereafter referred to as the Standard Specification\)](#). This document is obtainable separately, and Tenderers shall obtain their own copies of the applicable Sections.

<b>Part</b>	<b>Description</b>	<b>Date of Issue</b>	
0100	General	October	2020
0200	Services	October	2020
0300	Drainage	October	2020
0400	Earthworks and Pavement Layers: Material	October	2020
0500	Earthworks and Pavement Layers: Construction	October	2020
0600	Concrete Layers	October	2020
0700	Maintenance and Repair of Concrete Layers	October	2020
0800	Pre-treatment and Repair of Existing Layers	October	2020
0900	Asphalt Layers	October	2020
1000	Surface Treatments	October	2020
1100	Ancillary Road Works	October	2020
1200	Geotechnical Applications	October	2020
1300	Structures	October	2020
1400	Repair and Rehabilitation of Structures	October	2020
2000	Quality Assurance	October	2020

### C3.3.2 AMENDMENTS TO THE STANDARD SPECIFICATIONS

#### INTRODUCTION

In certain clauses the standard, standardized and particular specifications allow a choice to be specified in the project specifications between alternative materials or methods of construction and for additional requirements to be specified to suit a particular contract. Details of such alternative or additional requirements applicable to this contract are contained in this part of the project specifications. It also contains additional specifications required for this particular contract.

The number of each clause and each payment item in this part of the project specifications consists of the prefix **PS** followed by a number corresponding to the number of the relevant clause or payment item in the standard specifications. The number of a new clause or payment item, which does not form part of a clause or a payment item in the standard specifications and which is included here, is also prefixed by PS, but followed by a new number which follows on the last clause or item number used in the relevant section of the standard specifications.

PS C1	General
PS C2	Services
PS C3	Drainage
PS C4	Earthworks and Pavement Layers: Material
PS C5	Earthworks and Pavement Layers: Construction
PS C6	Concrete Layers
PS C7	Maintenance and Repair of Concrete Layers
PS C8	Pre-treatment and Repair to Existing Layers
PS C9	Asphalt Layers
PS C10	Surface Treatments
PS C11	Ancillary Roadworks
PS C12	Geotechnical Applications
PS C13	Structures
PS C14	Maintenance and Repair of Structures
PS C20	Quality Assurance



**PS C1 GENERAL****INDEX**

- PS.C1.1 GENERAL PREAMBLE**
- PS.C1.2 GENERAL REQUIREMENTS AND PROVISIONS**
- PS.C1.2.2.1 SUBMISSION OF A SCHEME 1 PROGRAMME**
- PS.C1.2.2.2 REVIEWING AND UPDATING A SHCEME 1 PROGRAMME**
- PS.C1.2.2.6 PREPARATION AND SUBMISSION OF INFORMATION AND REPORTS**
- PS.C1.2.4 STAKEHOLDER LIAISON**
- PS.C1.3 CONTRACTOR'S SITE ESTABLISHMENT AND GENERAL OBLIGATIONS**
- PS.C1.3.1 THE CONTRACTOR'S GENERAL OBLIGATIONS**
- PS.C1.5 ACCOMODATION OF TRAFFIC**
- PS.C1.7 LOADING AND HAULING**
- PS.C1.7.2.2 HAULING MATERIAL TO SPOIL**

**PS.C1.1 GENERAL PREAMBLE****Supply of plant, material and labour**

Except where otherwise specified the Contractor shall at his own expense supply and provide all the construction plant, temporary works, materials for both temporary and permanent works, labour (including supervision thereof), transport to and from the site and in and about the works and other things of every kind required for the construction, completion and where specified, maintenance of the works. The contractor shall also make his own arrangements with the proper authorities and at his own cost for the supply of water, electricity and any other services he may require for the construction and completion of the works.

**PS.C1.2.2 PROGRAMMING AND REPORTING****PS.C1.2.2.1 SUBMISSION OF A SCHEME 1 PROGRAMME**

Add the following paragraph to Clause A1.2.7.1(b):

The Contractor shall, on written instruction, provide the Engineer with a programme of works for specific projects that may arise within the contract duration.

**PS.C1.2.2.2 REVIEWING AND UPDATING A SHCEME 1 PROGRAMME**

Refer to COTO Specifications, Clause A1.2.7.1(d) – 'Updating and revising the programme.'

Only specified works and projects require monthly submissions of an updated programme at the end of every month.

**PS.C1.2.2.6 PREPARATION AND SUBMISSION OF INFORMATION AND REPORTS**

Add the following paragraph to clause A1.2.3.9 'Monthly reports.'

The Contractor shall submit monthly a progress report regarding Contractor Participation Goals (CPG) and a report on Full Time Equivalent Employment Information (FTE) as required by clause C.1.2.3.3 and C.1.2.3.4 of the Contract documentation. The Contractor shall submit monthly contract consumables such as progress photos, GIS Maps and Printing or as and when requested by the Engineer.

A provisional sum has been included in the BoQ for preparations of contract consumables and submissions thereof.

**Ps.C1.2.4 STAKEHOLDER LIAISON**

Refer to COTO Specifications, Part A1.2.3.18 – ‘Stakeholder Liaison.’

The stakeholder liaison shall be taken as the Project Manager/Engineer or otherwise specified during the Contract duration. Where new construction works are expected to be executed within certain ward(s), the ward Councillor(s) shall identify a Community Liaison Officer in accordance with clause C.1.2.3.1 of this document.

**MEASUREMENT AND PAYMENT**

The unit of measurement shall be part PC Sum that the service is provided during the approved contract period.

**PS.C1.3 CONTRACTOR'S SITE ESTABLISHMENT AND GENERAL OBLIGATIONS****PS.C1.3.1 THE CONTRACTOR'S GENERAL OBLIGATIONS**

In addition to the Standard Specification, the Contractors General Obligations shall also include:

- Training and supervision of local labour
- Management of labour where labour enhance construction methods are specified
- Compliance with, and application of the Compensation for Occupational Injuries and Diseases Act
- The Contractor's camp site and store yard.

NOTE: The Contractor's office for this contract shall be as and when required to fulfil his obligations under the Contract. The Contractor is responsible to provide a suitable site for his camp and to provide accommodation for his personnel and labourers.

The Employer has not made a site available to the contractor. If the Employer can make any specific site available to the Contractor, such site will be pointed out to the Contractor.

However, the Contractor may, if he prefers to, have a camp site at another location and must first obtain the written permission of the landowner, and subsequently the Engineer, to do so.

Any clearing of the site that is necessary and the making good after de-establishment will be the responsibility of the Contractor.

The following conditions shall also apply:

- None of the existing roads shall be damaged in any way. Should the road withstand any damage attributable to the Contractor's activities on site, the Contractor shall make good any damage caused at his own cost.
- It shall be the responsibility of the Contractor to make good any damage caused to the camp site area or any improvements on it, including services, and for reinstating it to its former condition when vacated. The standard of reinstatement must be to the satisfaction of the Engineer; Deputy Head: Real Estate and/or Deputy Head of Parks, Recreation and Beaches Department; or other owner. Particular attention should be directed to these requirements and written clearances from the relevant Departments or other owners will be required.

**PS.C1.5 ACCOMODATION OF TRAFFIC**

- a) No allowance has been made in the Bill of Quantities for deviations other than for the deviations mentioned in clause [PS 1.3.1](#). Costs of any other deviations required by the Contractor shall be included in the rates tendered. The other deviations required by the contractor shall be of Type A, unless otherwise stated by the Employers Agent.

- b) Deviations required by the Contractor shall comply with the requirements of [COTO 1.5](#). Details shall be submitted to the Employers Agent for approval at least [four weeks](#) in advance of date on which it is anticipated that work on the deviation will commence.
- c) On deviations provided in terms of (b) above the Contractor shall ensure at all times and during all weather conditions that all temporary surfaces that are intended to carry traffic are in fact trafficable with regard to reasonable standards of safety and comfort. No additional payment shall be made to the Contractor for compliance with this clause.
- d) Unless indicated otherwise over the entire length and for the duration of the contract, traffic is required to be accommodated in both directions at all times. The Contractor shall ensure that the full width of the road, or a width of road approved by the Employers Agent, is available for traffic during the peak traffic periods (i.e. 07:00 - 09:00 and 16:00 to 18:00).

#### **PS.C1.7      LOADING AND HAULING**

The Contractor shall make his own arrangements for the provision of a suitable approved dumping site off the site for the disposal of material obtained from excavations, demolition, clearing and grubbing, and rock cuttings. The rates in the Bill of Quantities are to include all costs of fees payable to cover the disposal of waste material at the dumping site.

##### **PS.C1.7.2.2      HAULING MATERIAL TO SPOIL**

###### **Approved tip Site**

The approved tip site is the Municipal refuse landfill. The Contractor will be permitted to offload spoil at any of the Municipal landfill sites provided the following requirements will have been fulfilled.

1. The Contractor shall have obtained a complete and signed authorisation form granting him/her permission to use such spoil sites.
2. Each vehicle shall have received such authorisation to be presented to the Landfill official upon entry.

The Contractor shall obtain a new authorisation for every day they intend to dispose of the material.

Any charges levied for dumping as a result of non-compliance with the above requirements will be for the Contractor's account.

The Contractor may choose to use other land as a tip site provided that a prior written approval of both the Engineer and Landlord/owner has been received. The Contractor may be called upon to prove when spoil is being dumped. Weighbridge slips will be the only acceptable proof in the case of the Municipal refuse dump.

**PS C12**      **GEOTECHNICAL APPLICATIONS****INDEX**

- PS.C12.3**      **GROUND IMPROVEMENTS**
- PS.C12.3.20**      **DUMPROCK**
- PS.C12.6**      **MECHANICALLY STABILISED EARTH WALLS**
- PS.C12.6.12.2**      **TERRACE BLOCK RETAINING WALL**
- PS.C12.6.16**      **GABION BASKETS**
- PS.C12.6.17**      **GEOTEXTILE**

**PS.C12.3**      **GROUND IMPROVEMENTS****PS.C12.3.20**      **DUMPROCK**

The dumprock shall consist of fresh to slightly weathered upgraded waste rock from mining activities, blasting or rock excavation. Shales, slates or other laminated mudrocks shall not be accepted.

Dumprock shall have a minimum size not more than two-thirds of the compacted thickness of the layer. The rock shall otherwise be upgraded but shall contain less than 10% passing the 37,5 mm sieve when spread on site. Dumprock shall have a minimum 10% FACT value of 100 kN when dry and 40 kN when tested drained after 24 hours soaking.

Dumprock shall be spread and levelled such that when compacted it is at the specified thickness and levels. When the correct road profile has been attained the dumprock layer shall be rolled 5 passes of a 10/12 ton static three wheel steel roller or equivalent vibrating roller. Dry, fine material (13,2 mm down) with a Plastic Index of between 0 and 7 shall then be applied in a blanket over the full width of the layer. With hand labour following the roller, the fine material shall be rolled and broomed into the voids of the stone. This procedure shall be repeated until the stone layer will accept no further fines.

Compaction of the layer shall continue until movement of the material under the compactor becomes negligible or for a maximum of 10 passes of the roller whichever occurs first.

The completed dumprock layer shall be measured in cubic metre (m<sup>3</sup>). The rate shall cover the supply, loading, transporting, dumping, spreading of all materials and all processing of the layer and proof rolling, all as detailed.

**PS.C12.6**      **MECHANICALLY STABILISED EARTH WALLS****PS.C12.6.12.2**      **TERRACE BLOCK RETAINING WALL**

The Contractor shall repair and replace all damaged and missing masonry blocks that matches the existing masonry blocks and the bond must be the same as the existing.

**Construction**

Lay the first course of blocks at 300mm spacing on level or angled base. Use a unique patented slider system that easily fits on the spacing between the blocks. Interlocking blocks of the second course shall be centrally stacked to span between the two blocks of the lower course. The blocks shall be levelled with a straight edge spirit level. Long stretches of walling system, the Contractor shall use a fish line around the outermost blocks and the rest of the blocks shall be matched against this line. All loose soil behind the wall shall be hand compacted and wetted row by row to mitigate settlement issues at a later stage.

The measurement for this item shall be the square meter of TB500 blocks installed, repaired or replaced. The Contractor's rate to include for the procurement, loading, unloading, and installing TB500 blocks.

**PS.C12.6.16 GABION BASKETS****Wire**

All wire used for fabrication of the mesh and the lacing, bracing and connecting of cages shall be mild steel conforming to S.A.B.S. 675 with a Class A zinc coating or equivalent and, in additions, shall be plastic coated.

The zinc coating shall have a mass per unit area at least equal to the value tabulated below.

Table 1: Minimum mass of zinc coating

Nominal Diameter of wire		Minimum Mass of Zinc Coating per Unit Area g/m <sup>2</sup>
Over mm	Up to and including mm	
1,8	2.24	240
1,8	2.72	260
2.72	3.55	275

The plastic coating shall be of grey or black polyvinyl chloride applied by an extrusion process with a nominal thickness of at least 0,50 mm and a thickness at no point of less than 0,45 mm. After the weaving and binding operations, it shall be capable of resisting without cracking the deleterious effects of exposure to intermittent water spraying and continuous light when tested for a period of not less than 3 000 hours in accordance with the latest approved A.S.T.M. Standards G23-81 and D1499-64. It shall satisfy the tests for bonding to the wire core, salt corrosion and creeping corrosion as specified in clause 7.5 of S.A.B.S. 1 200 DK.

**Mesh**

The wire shall be machine woven into an hexagonal mesh, the joints being formed by twisting each pair of wires through not less than one and a half turns.

**Woven Cages**

The gabion mesh shall be supplied cut, selvaged and ready for folding into a rectangular cage complete with lid, and panels, and diaphragms dividing the cage into compartments.

All panel edges which are required to be laced on site shall be selvaged. Selvage wires shall be woven integrally with the mesh, except at cut ends where they shall be tightly bound to the cut wire.

Sufficient plastic-coated galvanised wire for lacing, bracing and connecting shall be supplied with the gabion cages to complete all the wiring operations that are necessary for the assembly and installation of the cages.

**Rockfill**

The rock fill shall consist of clean, hard unweathered rock fragments free from fissures and flaking and shall be placed in gabions by hand.

**Dimensions of Gabions with Rockfill**

The dimensions of the wire, mesh and rock filling shall be as shown in Table 2: Dimensions of Gabions and Rock Fill.

**Table 2: Dimensions of Gabions and Rock Fill**

Gabion Description		Diaphragm Mean Spacing	Wire mesh Woven		Rockfill Largest Dimensions		Minimum Nominal Diameter of Zinc-Coated Steel wire			
Type	Depth mm		b mm	1 mm	Min. mm	Max. mm	Mesh mm	Selvedge mm	Lacing mm	Bracing mm
Mattress	230	600	60	80	75	150	2.0	2.4	2.0	2.0
	300	600	60	80	75	150	2.0	2.4	2.0	2.0
		600	80	100	100	150	2.2	2.7		
Box	500	1000	80	100	100	150	2.4	3.0	2.0	2.0
		1000	100	120	150	225	2.4	3.0	2.0	2.0
	1000	1000	80	100	100	150	2.4	3.0	2.0	2.0
1000		100	120	150	225	2.7	3.4	2.0	2.0	

**NOTES:**

1. b - a nominal dimension measured between the centres of the parallel twisted sides of the hexagon.
2. 1 - a nominal dimension measured at right angles to "b" between the ends of the in-line twists.
3. The minimum dimension of rock fill shall be such that no rock shall pass through a ring of diameter 10% greater than b while the maximum largest dimension shall be as shown in the table above.

**Measurement and Payment**

The unit of measurement shall be the cubic metre of the rock-filled boxes or mattresses and the quantity shall be calculated from the dimensions of the gabions indicated on the drawings irrespective of any accepted deformation or bulging of the completed gabions. Gabions boxes and mattresses shall be measured to the nearest specified size.

The tendered rates shall include full compensation for supplying all the materials, including rock fill, wire-mesh boxes, galvanizing, PVC-coating, tying and connecting wires, loading, transporting and off-loading, the assembling and filling of the boxes, disposal of waste, and any other work necessary for constructing the gabions.

Placing of rock by dumping shall not be allowed and the tendered rates shall also include full compensation for placing rock by means of hand labour.

**PS.C12.6.17 GEOTEXTILES**

The synthetic fibres of a geotextile blanket shall consist of at least 100% by mass of polypropylene, polyethylene or a polyester polymer and shall contain such additives as are necessary to render the filaments resistant to the effects of ultraviolet radiation in accordance with the following requirement: The geotextile shall retain 80% of its specified strength after an effective exposure period of 1500 hours to direct sunlight.

The grade of geotextile shall conform to Table 1 of SABS 0221-1988:

TABLE 1 - GRADES OF GEOTEXTILES

1	2	3	4	5	6	7	8	9	10	11
Property	Grades									
	1	2	3	4	5	6	7	8	9	10
Thickness, mm	Minimum value									
	as specified by manufacturer									
Mass per unit area, g/m <sup>2</sup>	100	100	140	140	200	200	240	240	300	300
Penetration load, kN	1.0	1.0	1.5	1.5	2.5	2.5	3.0	3.0	4.0	5.0
Tensile strength, kN/m	6	6	10	10	13	13	18	18	25	30
Permeability, 1/s.m <sup>2</sup>										
High flow	200	-	170	-	130	-	80	-	40	-
Low flow	-	25	-	20	-	15	-	10	-	5

**PS C13**      **CONCRETE****INDEX****PS.C13.2**      **FALSEWORK, FORMWORK AND CONCRETE FINISH****PS.C13.4**      **CONCRETE****PS.C13.4.1**      **CAST INSITU CONCRETE****PS.C13.4.9**      **PRECAST CONCRETE****PS.C13.2**      **FALSEWORK, FORMWORK AND CONCRETE FINISH****Falsework and Formwork**

All formwork surfaces in contact with proprietary concrete repairs shall have received treatment with a suitable mould release agent. The formwork surfaces shall match the existing surfaces and textures as close as is practically possible.

**Concrete Finish**

The following finishes as specified in the Standard Engineering Specifications Clause A13.2.7.2, shall apply to formed pre-cast and cast in-situ concrete surfaces.

**1. Class F1 surface finish**

After repair work has been done to surface defects in accordance with Clause A13.2.7.4, no further treatment of the as-stripped finish will be required. This finish is required on concealed formed surfaces.

**2. Class F2 surface finish**

This finish shall be equivalent to that obtained from the use of square-edged timber panels and boards wrought to the correct thickness, or shutter boards or steel forms arranged in a regular pattern. This finish is intended to be left as struck but surface defects shall be remedied in accordance with Clause A13.2.7.4. Although minor surface blemishes and slight discolourations will be permitted, large blemishes and severe stains and discolouration shall be repaired where so directed by the Engineer.

**3. Class F3 surface finish**

This finish shall be that obtained by first producing a class F2 surface finish with joint marks which form an approved regular pattern to fit in with the appearance of the structure. All projections shall then be removed, irregularities repaired and the surface rubbed or treated to form a smooth finish of uniform texture, appearance and colour. This surface finish is required on all exposed formed surfaces unless a class F2 finish is specified.

Unless specified to the contrary, steel forms may be used to form surfaces with a class F3 surface finish.

The use of steel forms shall be permitted to form surfaces for which Class F3 surface finish has been specified, provided that only undamaged forms shall be used for such work and that the forms shall be subject to the approval of the Engineer.

**4. Board surface finish**

This finish shall be that obtained by using tongue-and-groove timber boarding arranged in an approved regular pattern. The finish is intended to be left as struck but surface defects shall be remedied in accordance with Clause A13.2.7.4 and large fins trimmed where directed by the Engineer.

**PS.C13.4 CONCRETE**

**PS.C13.4.1 CAST INSITU CONCRETE**

No concrete is to be placed in the formwork until the section receiving concrete has been inspected and approved by the Engineer.

The complete upper surface of the existing concrete shall be thoroughly scabbled to expose sound aggregates. All dust and debris shall be cleaned and removed from the scabbled surface.

**PS.C13.4.9 PRECAST CONCRETE**

Precast concrete shall be of Class C28/35-20 concrete. Precast members shall have a minimum strength of 25MPa before handling. The Contractor shall submit test results for precast concrete strengths at 7 and 28 days.



**PS C14      REPAIR AND REHABILITATION OF STRUCTURES****INDEX**

<b>PS.C14.1</b>	<b>ACCESS FOR BRIDGE REHABILITATION</b>
<b>PS.C14.1.1</b>	<b>TEMPORARY ACCESS STRUCTURES AND WORK PLATFORMS</b>
<b>PS.C14.4</b>	<b>SURFACE AND STRUCTURAL REPAIR OF CONCRETE MEMBERS</b>
<b>PS.C14.4.1</b>	<b>CEMENTITIOUS MORTAR OR CONCRETE</b>
<b>PS.C14.4.2</b>	<b>EPOXY MORTAR</b>
<b>PS.C14.5</b>	<b>ANCHORING OF REINFORCEMENT, GROUTING AND CRACK INJECTION</b>
<b>PS.C14.5.3</b>	<b>GROUTING FOR GAP FILLING</b>
<b>PS.C14.5.5</b>	<b>SURFACE PREPARATIONS FOR CRACK INJECTIONS</b>
<b>PS.C14.5.6</b>	<b>CRACK INJECTIONS</b>
<b>PS.C14.9</b>	<b>REPAIR AND REPLACEMENT OF ANCILLARY STRUCTURAL ELEMENTS</b>
<b>PS.C14.9.2</b>	<b>RETAINING WALL DRAINAGE SYSTEM</b>
<b>PS.C14.9.6</b>	<b>BALL TYPE AND POLYCRETE HANDRAIL REPAIRS</b>
<b>PS.C14.9.7</b>	<b>REMOVAL AND REINSTATEMENT OF BRICKWORK</b>
<b>PS.C14.9.14</b>	<b>BRIDGE NUMBER PLATES</b>

**PS.C14.1      ACCESS FOR BRIDGE REHABILITATION****PS.C14.1.1      TEMPORARY ACCESS STRUCTURES AND WORK PLATFORMS**

Add the following to clause C14.1.1:

The unit of measurement shall be the lump-sum.

The height requiring access platforms shall be 1.5 metres or more and shall be required for a minimum rehabilitation area of 50m<sup>2</sup> unless instructed otherwise by an engineer. The heights shall be assessed by the Contractor and agreed with the Engineer prior to commencement of works requiring access.

The tendered amount shall include full compensation for design, supply, fabrication, erection, dismantling, movement and for all labour, materials, and equipment required for work platforms including inspections and supervision by the safety officer and the maintenance of the temporary access structure and work platforms.

Payment shall be made on the following basis: - 70% of the lump-sum on erection of access structures.  
-30% of the lump-sum on removal of access structures.

**PS.C14.4      SURFACE AND STRUCTURAL REPAIR OF CONCRETE MEMBERS****Spall Repair Preparation**

All spalled, cracked, rust stained or unsound concrete shall be removed by mechanical means to expose the full extent of the corroded reinforcement.

The Contractor shall continue to remove the concrete surrounding the reinforcement until at least 50mm of unruined steel is exposed at both ends of the corroded sections.

The perimeter of the spall shall be sawcut to at least 10mm to eliminate feather edges. The sides of the spall area shall be perpendicular to the upper concrete surface adjacent to the spall.

At least 10mm of concrete shall be removed from behind the full length of the exposed portion of reinforcement. Where necessary, additional concrete shall be removed from behind the rebar and the rebar hammered into the recess so that it is at least 50mm from the general surface of the concrete. i.e. the depth of the recess shall be at least 50mm plus the diameter of rebar plus 10mm below the rebar.

## **Preparation and protection of embedded reinforcement**

All visible or embedded reinforcement bars showing signs of corrosion shall be exposed by cutting back the concrete around the bar with pneumatic chisels or other approved method. The corrosion shall be removed by grit blasting, or where this is not warranted, by wire-brushing with power tools to an acceptable surface. The treated steel surface shall be clean of all corrosion and foreign material likely to impair the bond of the anti-corrosion primer to the reinforcement. No chemical solvents shall be used without the approval of the Engineer.

Reinforcement that has experienced significant pitting or reduction in diameter shall be referred to the Engineer for acceptance. All rejected reinforcement shall be cut out and replaced with new bars of the same type and size, allowing for a minimum overlap of 45 diameters with the in situ bars.

All exposed and cleaned reinforcement shall receive one coat of a single-component anti-corrosion primer based on zinc and epoxy resins, such as that of Pro-Struct 688 or similar approved, which shall be evenly applied to achieve a minimum 40 µm dry film thickness. The primer shall contain at least 30 % zinc solids by volume. The primed surface shall not be exposed to the atmosphere longer than specified by the manufacturer primer before the application of the repair mortar, but at least until the coating is fully dry.

Alternative proprietary anti-corrosion coatings shall be subject to the approval of the Engineer, based on submitted test documentation and proven performance within the industry.

In cases where the final concrete cover is deemed by the Engineer to be inadequate the following protection shall be applied at the Engineer's instruction:

- Cover 0 – 5,0 mm

The reinforcement shall receive two coats of anti-corrosion zinc-based epoxy primer as described previously. In order to improve the bond to the covering epoxy mortar, kiln-dry quartzitic sand shall be applied onto the final wet coat.

- Cover >5,0 mm

The outer surface mortar patch shall receive a surface coating based on an approved hydrophobic impregnants, sealers and pore blockers, or coatings complying with Clause A14.7.5. Where an epoxy mortar is used as repair material, the reinforcement shall be coated as for the 0 – 5,0 mm case.

### **PS.C14.4.1 CEMENTITIOUS MORTAR OR CONCRETE**

Add the following to clause A14.4.7.2(a):

#### **Reinstatement of Concrete Profiles**

The nature and size of the repairs will dictate the type of repairs required. The Contractor shall use formwork and an aggregate filled non-shrink concrete systems where it is reasonable and practically possible.

#### **Non-Shrink mortar repairs**

Areas that require large volume of repair material shall be made good using a non-shrink cementitious material such as the pro-Struct 528/529 – Five Star Structural Concrete or approved equivalent, suitably filled with aggregates as per manufacturer's instructions.

Surface preparations shall be as detailed in COTO standard specifications. The profile of the repair area shall be cut in such a way so as to prevent air entrapment when grouting.

Shuttering shall be watertight and capable of supporting the concrete in the correct position. The

shutters shall be designed in such a way that exposed surfaces of the newly placed concrete is minimal.

After fixing the shutter into position, the existing concrete shall be pre-wetted in accordance with the concrete manufacturer's instructions or by flooding the shutters with portable water where no manufacturer's instruction is given.

The Contractor shall drain all water from the shutters before placing concrete. The Contractor may place concrete by means of letterbox openings in the shutter, large funnels, or by grouting pumps. Concrete flow must be continuous until the shutter is full and the Contractor can achieve this by rodding or strapping. Vibrators shall not be used for this purpose.

The mixing and application of the concrete shall be with strict adherence to the manufacturer's instructions. Under no circumstance shall the water/cement ratio of the powder be exceeded.

Repair areas shall be cured as described in clause C14.4.4 of COTO standard specifications.

#### **PS.C14.4.2 EPOXY MORTAR**

All areas receiving mortar repairs shall be blown clean with oil free compressed air. The clean area shall be thoroughly saturated with water to eliminate 'grab'.

The concrete profiles shall be restored with Pro-Struct 528/529 – Five star Structural Concrete or approved equivalent. The repair material shall be a high build cementitious type containing non-shrink cements, graded sands, fillers and chemical additives with water repellent qualities. The patches shall be cured with strict adherence to the manufacturer's instructions.

#### **PS.C14.5 ANCHORING OF REINFORCEMENT, GROUTING AND CRACK INJECTION**

##### **PS.C14.5.3 GROUTING FOR GAP FILLING**

##### **PS.C14.5.5 SURFACE PREPARATIONS FOR CRACK INJECTIONS**

All cracks greater than 0.2mm shall be sealed in accordance with the method described hereunder. The entire length of the crack shall be wire brushed and a vee cut (10mm deep and 20mm wide) chased along the length of the crack.

Holes for grease nipples shall be drilled into the crack at 250mm c/c and at least 50mm deep.

NOTE: Cracks on both sides of the concrete member shall have nipple holes on one side of the concrete member positioned midway relative to those on the opposite side.

On completion, all dust and debris shall be removed with oil free compressed air.

Grease nipples shall be fixed into the holes with an epoxy paste. The Contractor shall ensure that the heads of the nipples are protected from the epoxy paste.

The remainder of the vee cut shall be sealed off with an epoxy paste and left to cure overnight.

##### **PS.C14.5.6 CRACK INJECTIONS**

The non-return ball valves of the nipples shall be opened by forcing in pins.

A low viscosity epoxy of an approved manufacturer shall be pumped into the crack starting at the lowest nipple and progressing to next nipple as the resin is extruded from the nipples. After thirty (30) minutes, the sequence shall be repeated until the crack is fully injected.

Once injection of the crack has started, work shall continue until the crack is filled. After 24 hours (one full day) of injection, all protruding nipples shall be cut off with a grinding wheel.

#### **PS.C14.9 REPAIR AND REPLACEMENT OF ANCILLARY STRUCTURAL ELEMENTS**

##### **PS.C14.9.2 RETAINING WALL DRAINAGE SYSTEM**

Add the following to clause C14.9.2.

The Contractor shall repair all broken/damaged 50mm diameter PVC drainage systems on retaining walls. All blocked drainage systems on specified retaining walls shall be cleared initially removing the blockage at the entrance to the drainage system.

The remaining blockages in the drainage system shall be cleared using high pressure water jetting.

##### **PS.C14.9.6 BALL TYPE AND POLYCRETE HANDRAIL REPAIRS**

###### **Steel Ball Type Handrail Repairs**

The Contractor shall repair the damaged handrail/ knee rail / ball type stanchions system on specified retaining walls. The handrail component shall be hot-deep galvanised and match the existing handrail in all respect. The Contractor shall weld the stanchions and rails together to prevent theft. The welds shall be 6mm fillet welds. The welds are to be cleaned of weld slag and painted with two (2) coats of a zinc rich primer of an approved manufacturer.

###### **Polycrete Handrail Repairs**

The Contractor shall repair all damaged handrailing system on specified retaining walls. The replacement of handrails and balustrades shall conform to the requirements of TMH 7 – Parts 1 and 2 for loading on balustrades and signed off by a person professionally registered with the Engineering Council of South Africa.

The reinforcement shall be hot deep galvanised high tensile steel. The material used to form the handrail system shall be a resin bound cementitious material of high compressive strength. The finish of the installed replacement handrail shall match the existing handrail system in all respects.

##### **PS.C14.9.7 REMOVAL AND REINSTATEMENT OF BRICKWORK**

###### **Broken Masonry Blocks**

The Contractor shall repair and replace all damaged and missing masonry blocks, the blocks replaced shall match the existing masonry blocks and the bond shall be the same as the existing.

##### **PS.C14.9.14 BRIDGE NUMBER PLATES**

Bridge number plate shall conform to the below construction drawing “ Asset Management System”.

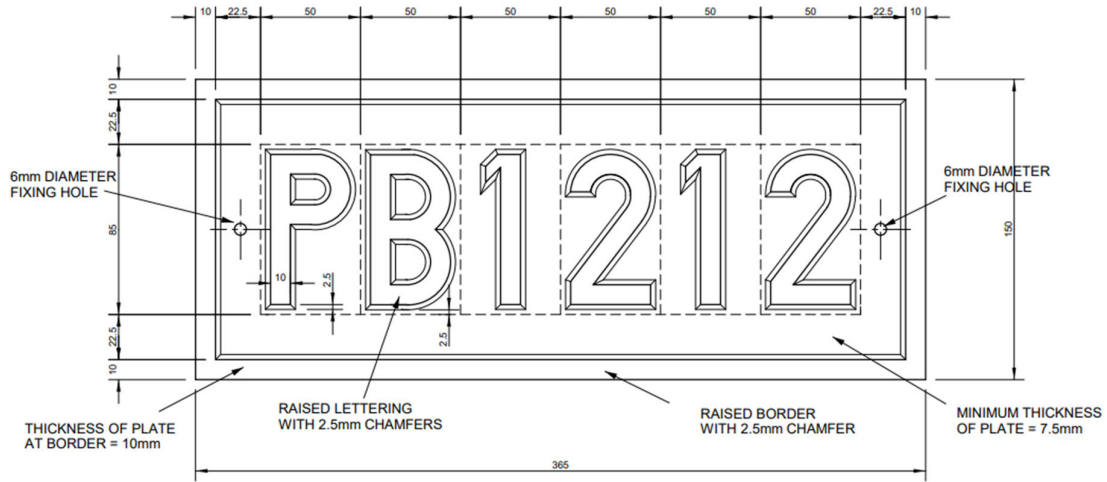

NOTES :

1. ASSET NUMBER PLATES TO BE MANUFACTURED WITH POLYMER CONCRETE THE BINDER OF WHICH SHALL BE UV STABILISED
2. THE RAISED LETTERING AND BORDER TO BE BLACK ON WHITE BACKGROUND
3. THE MANUFACTURED PLATES SHALL BE FIXED TO THE STRUCTURE AT THE POSITIONS INDICATED ON SITE
4. THE SURFACE OF THE STRUCTURE IN CONTACT WITH THE ASSET NUMBER PLATE SHALL BE SCABBLED AND CLEANED OF ALL DUST AND DEBRIS
5. THE ASSET NUMBER PLATE SHALL BE FIXED TO THE PREPARED SURFACE OF THE STRUCTURE USING A COMBINATION OF A GENERAL EPOXY ADHESIVE AND TWO STAINLESS STEEL SCREWS WITH LIGHT DUTY IMPACT ANCHORS
6. ALL COMPONENTS SHALL BE OF APPROVED MANUFACTURE

## ASSET MANAGEMENT SYSTEM

BRIDGE & RETAINING WALL ASSET NUMBER PLATE DETAIL

### **C3.4: PARTICULAR SPECIFICATIONS**

In addition to the Standardized and Project Specifications the following Particular Specifications / Policies shall apply to this contract:

- C3.4.1 Part AH - OSHA 1993 Safety Specification  
(26 Pages)
  
- C3.4.2 Standard Environmental Management Plan for Civil Engineering Construction Works  
(24 Pages)

**C3.5: CONTRACT AND STANDARD DRAWINGS****C3.5.1 CONTRACT DRAWINGS / DETAILS**

List the drawings here

**C3.5.2 STANDARD DRAWINGS**

The Standard Drawings to which these Standard Engineering Specifications refer are listed below.

<b>Dwg No</b>	<b>Description</b>	<b>Date of Issue</b>	
38570	Ring Manholes	February	1990
38571	Brick Manhole Details	February	1990
38572	Stormwater Inlet Details	February	1990
38573	Stormwater Inlet Special Details	February	1990
38574	Sewer Manholes: Ramp, Backdrop and Channelling Details	February	1990
38575	Sub-Soil Drain, Pipe Bedding and Pipe Protection Details	February	1990
38576	Headwall Details	February	1990
38577	Kerbing Details	February	1990
38578	Concrete Median Barriers	February	1990
38579	Vehicular and Pedestrian Scoops	February	1990
38580	Concrete Bollard and Steel Guard Rail	February	1990
38581	Retaining Wall, PC Steps, Staircase, Cable Ducts and Headwalls	February	1990
38582	Precast Concrete Fencing and Aluminium Gates	February	1990
38583	Wire Mesh Fence and Gate Details	February	1990
38584	Standard Hydrant Thrust Blocks and Trenches	February	1990
38585	Water Connections, Pipework and Fittings	February	1990
38586	DP & TC Manholes - Rectangular	February	1990
38587	DP & TC Manholes - "L" Shaped	February	1990
38588	DP & TC Manholes - "T" Shaped	February	1990
38589	DP & TC Cable Ducts and Junction Box Details	February	1990
43120	Typical Details of Grid Inlets	February	1990

**C3.6: ANNEXURES**

**C3.6.1**     **There are no Annexures.**



**PART C4: SITE INFORMATION**

**C4.1 LOCALITY PLAN**  
eThekweni Metropolitan Area

**C4.2 CONDITIONS ON SITE**  
There is no specific geotechnical information or other site information.

**C4.3 TEST RESULTS**  
There are no specific test results.